

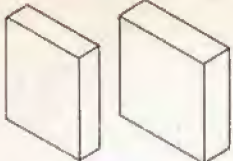









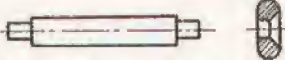

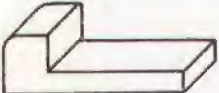
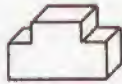

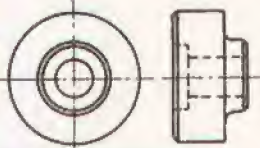
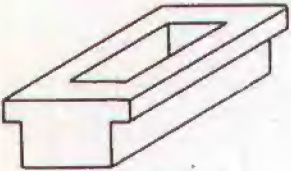
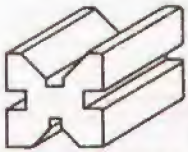
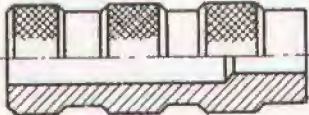

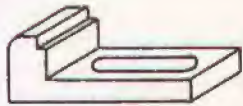

TRADE TRAINING ATC PROGRAMME

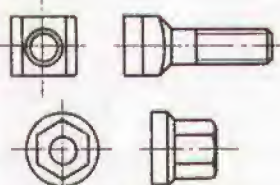
MACHINIST

DEVELOPMENT CELL
FOR SKILLED LABOUR TRAINING
DIRECTORATE OF MANPOWER & TRAINING
GOVERNMENT OF THE PUNJAB
LAHORE

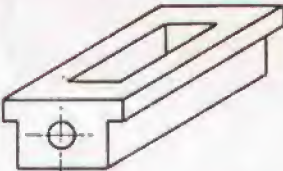

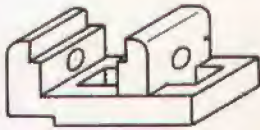
SHAPING 2.2.2 / 0.1 - 0.6		TURNING 2.2.3 / 0.1 - 0.6	
 Parallel, Square-Shaping 1 → 2.3.5/3 1a → 2.1.2/12	 Parallel, Angular-Shaping 2 → 2.3.5/3	 Longitudinal Turning, Drilling, Form Turning 1 → 2.3.5/3	 Step Turning, Threading 2 → 2.3.5/3
 Parallel, Step-Shaping 3 → 2.2.4/4	 Parallel, Step-Shaping 4 → 2.2.4/5	 Taper Turning, Turning of ISO-Fits 3 → 3.2.2/8	 Mandrel Work, Boring 4 → 2.2.4/11
 Form Shaping 5 → 2.2.4/10	 Form Shaping 6	 Knurling 5 → 3.3.4/1	 Grooving, Reaming 6 → 2.4.3/2
MILLING 2.2.4 / 0.1-12			
 Plain and Square Milling 1 → 2.2.4/8	 Slot Milling 2.1.3/5 → 2	 Step Milling 3	 Slot Milling, Step Milling 2.2.2/3 → 4 → 2.3.5/3
 Milling to High Accuracy 2.2.2/4 → 5 → 2.3.5/3	 Dividing Head Work 2.1.2/11 → 6	 Keyway Milling 2.1.2/3 → 7 → 2.3.5/4	 Form Milling 2.2.4/1 → 8 → 2.3.5/3
 Step Milling, Slot Milling 2.1.3/4 → 9 → 3.3.4/1	 Drilling and Reaming 2.2.2/5 → 10 → 3.3.4/1	 Gear Milling 2.2.3/4 → 11 → 2.3.5/4	 Form Milling 2.3.5/3 → 12 → 2.3.5/3

TRADE TRAINING

LAYOUT

No. 2.2.2
No. 2.2.3
No. 2.2.4



DEVELOPMENT CELL FOR SKILLED LABOUR TRAINING

PAK-GERMAN TECHNICAL TRAINING PROGRAMME

MACHINIST

MATERIAL REQUIRED

Trade Training for Machinist

Shaping No. 2.2.2	Exercise No. (Length given in millimeter)						Length per trainee	Total length for a batch of 16 trainees
	1	2	3	4	5	6		
M/S Flat 35 x 8 mm (1 1/2 x 3/8)	52						52 mm	0,9 meter
M/S Square 50 x 50 mm (2" x 2")			106	26			132 mm	2,3 meter
Low carbon steel Flat 100 x 10 mm (4" x 3/8)		17					17 mm	0,4 meter
Carbon steel Square 50 x 50 mm (2" x 2")					83		83 mm	1,4 meter
Cast iron according pattern					X			
Turning No. 2.2.3								
M/S Round 10 mm (3/8)	118						118 mm	2,0 meter
M/S Round 15 mm (5/8)	20	12					32 mm	0,6 meter
M/S Round 25 mm (1")		140					140 mm	2,4 meter
M/S Round 30 mm (1 1/4)					115		115 mm	2,0 meter
M/S Round 65 mm (2 1/2)				28			28 mm	0,6 meter
Low carbon steel Round 15 mm (1/2)						35	35 mm	0,7 meter
Low carbon steel Round 25 mm (1")						90	90 mm	1,6 meter
High speed steel Round 25 mm (1")			143				143 mm	2,4 meter
Milling No. 2.2.4								
M/S Square 50 x 50 mm (2" x 2")	55	3					Length per trainee	Total length for a batch of 16 trainees
M/S Square 35 x 35 (1 1/2 x 1 1/2)		45					55 mm	1,0 meter
							45 mm	0,8 meter



DEVELOPMENT CELL FOR SKILLED LABOUR TRAINING

PAK-GERMAN TECHNICAL TRAINING PROGRAMME

MACHINIST

5 

Tolerance ± 0.1

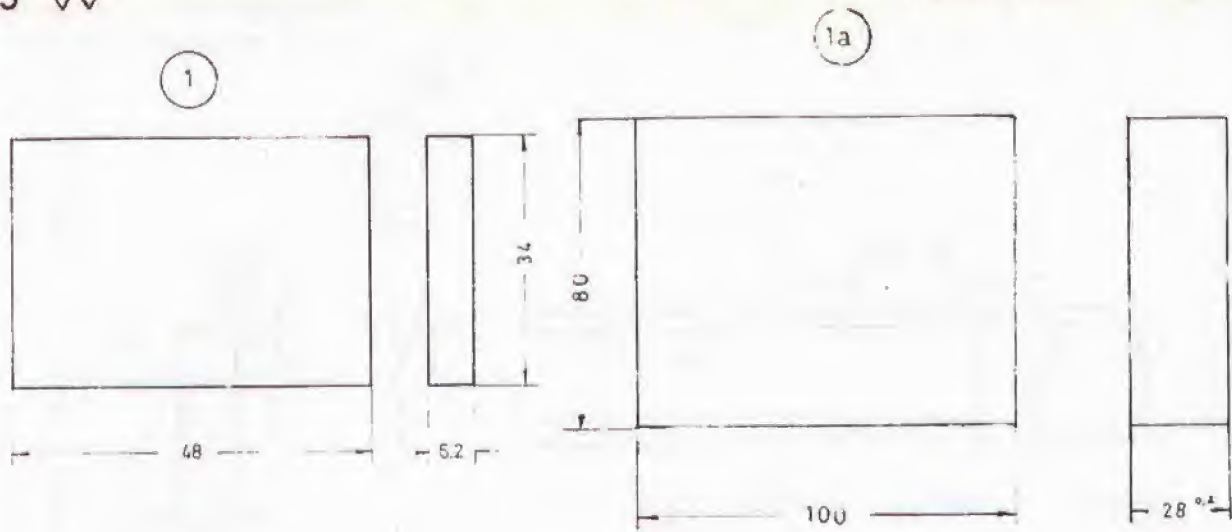

Material Provided from TURNER 2.1.2/12
for 1a

SEQUENCE OF OPERATIONS

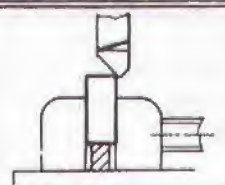
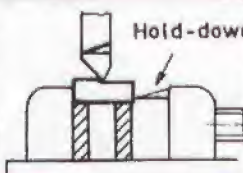
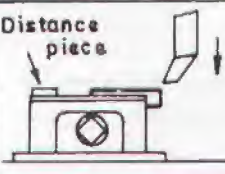
No.	Symbol	Tools	Descriptions
1		STRAIGHT LEFT HAND CUTTING TOOL PARALLEL BAR VERNIER CALIPER	SQUARE AND PARALLEL SHAPING OF SIZE 34 MM
2		STRAIGHT LEFT HAND CUTTING TOOL PARALLELS AND HOLD DOWN DEPTH GAUGE	CLAMPING OF A THIN PIECE WITH THE HELP OF A HOLD DOWN. PARALLEL SHAPING
3		SIDE CUTTING TOOL PARALLELS TRY SQUARE	SHAPING IN VERTICAL DIRECTION. USING A DISTANCE PIECE FOR PROPER CLAMPING
4		AFTER EACH SHAPING OPERATION DEBURR THE WORKPIECE BY USING A SMOOTH FLAT FILE. NUMBER PUNCHING.	

Ex. 1a for Tur / Turning II

SCALE 1:1

MAT.: MILD STEEL

END PLATE

(Ex. 1 For bench vice)

No. 2.2.2/01-1a

SHAPING II



DEVELOPMENT CELL FOR SKILLED LABOUR TRAINING

PAK-GERMAN TECHNICAL TRAINING PROGRAMME



MACHINIST

4 

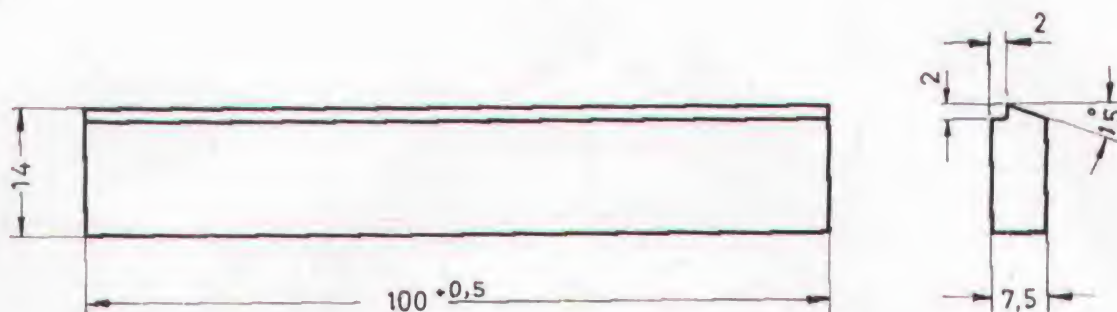
Tolerance $\pm 0,1$
unless otherwise stated



SEQUENCE OF OPERATIONS

No.	Symbol	Tools	Descriptions
1		STRAIGHT LEFT HAND CUTTING TOOL	SQUARE AND PARALLEL SHAPING TO GIVEN DIMENSIONS
2		SIDE CUTTING TOOL PARALLELS TRY SQUARE	VERTICAL SHAPING
3		STRAIGHT LEFT HAND CUTTING TOOL BEVEL PROTRACTOR MARKING TOOLS	HORIZONTAL SHAPING UP TO MARKING LINE

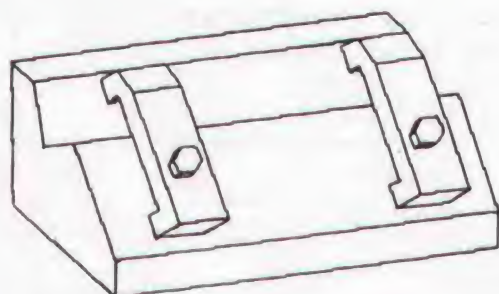

SINCE CLAMPING AND MACHINING OF THE LONG AND THIN WORKPIECE REQUIRES MUCH EXPERIENCE, IT IS RECOMMENDED TO PROVIDE THE TRAINEE WITH A FIXTURE AS SHOWN IN THE SKETCH.

SCALE 1:1

MAT. : LOW CARBON - STEEL

JAW

(For bench vice)

No. 2.2.2/02

SHAPING II



DEVELOPMENT CELL FOR SKILLED LABOUR TRAINING

PAK-GERMAN TECHNICAL TRAINING PROGRAMME

MACHINIST

1 

Tolerance $\pm 0,1$
unless otherwise stated

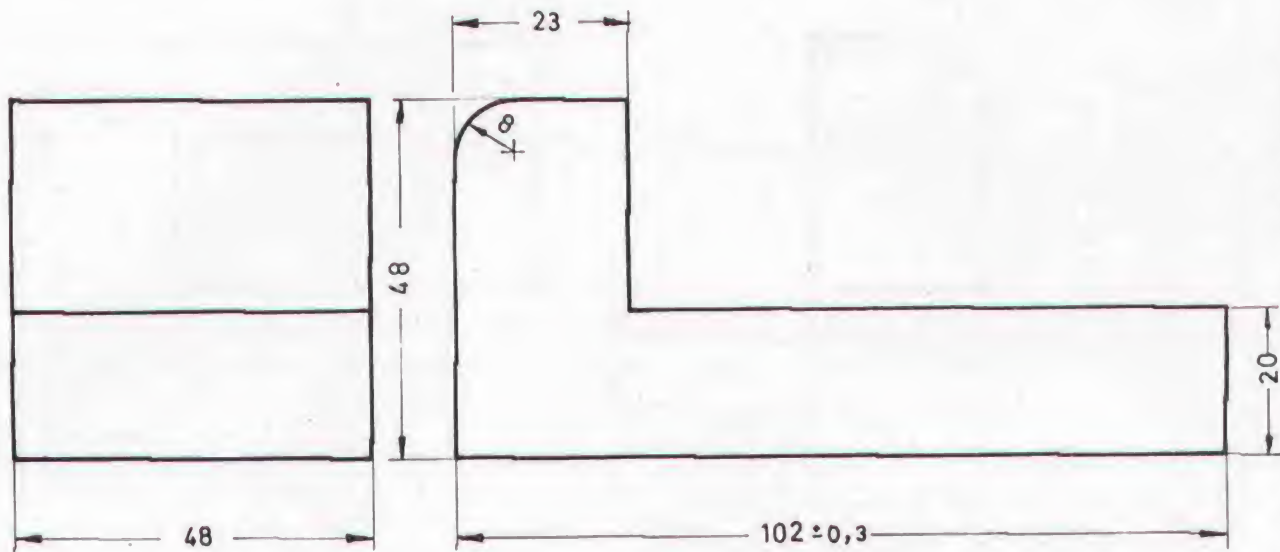

See Ex. 2.2.4/4

SEQUENCE OF OPERATIONS

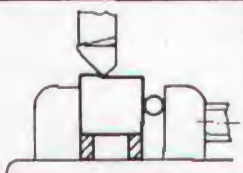
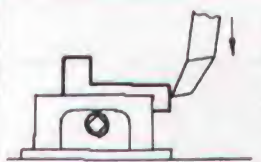
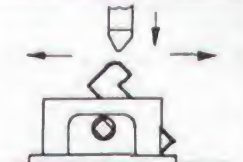
No.	Symbol	Tools	Descriptions
1		STRAIGHT LEFT HAND CUTTING TOOL PARALLELS ROUND BAR	SQUARE AND PARALLEL SHAPING TO GIVEN DIMENSIONS
2		SIDE CUTTING TOOL DEPTH GAUGE	STEP SHAPING
3		ROUND-NOSE ROUGHING TOOL	FORM SHAPING ACCORDING MARKING LINE

SCALE 1:1

MAT.: MILD STEEL

FIXED JAW

(For bench vice)

No. 2.2.2 / 03

SHAPING II



DEVELOPMENT CELL FOR SKILLED LABOUR TRAINING

PAK-GERMAN TECHNICAL TRAINING PROGRAMME



MACHINIST

2 

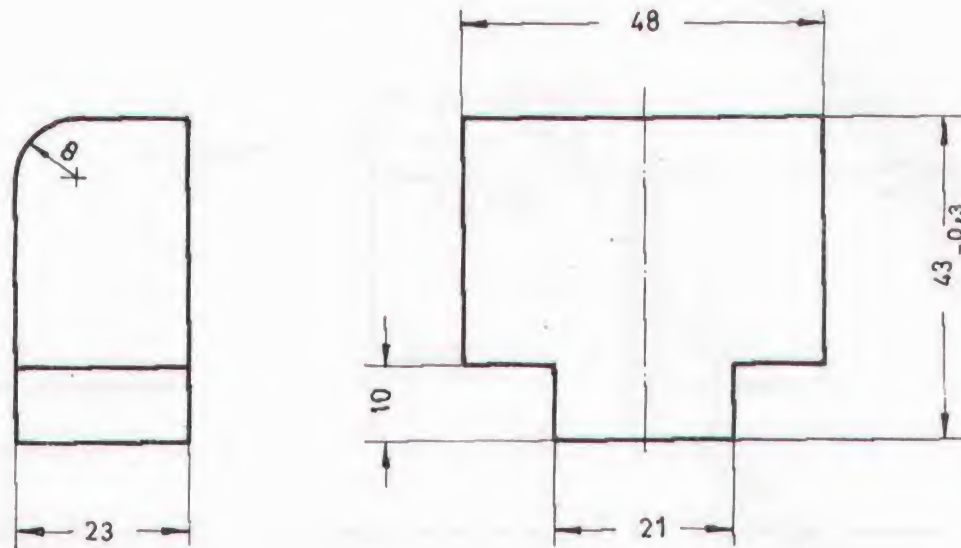
Tolerance ± 0.1
unless otherwise stated

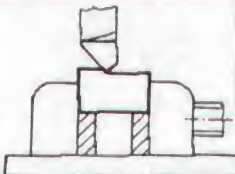
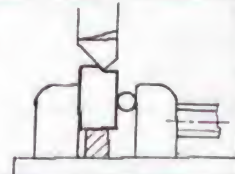
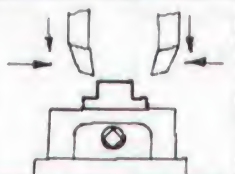

SEQUENCE OF OPERATIONS

No.	Symbol	Tools	Descriptions
1		STRAIGHT LEFT HAND CUTTING TOOL PARALLELS	PLAN SHAPING OF REFERENCE SURFACE
2		STRAIGHT LEFT HAND CUTTING TOOL ROUND BAR PARALLEL	SQUARE AND PARALLEL SHAPING TO GIVEN DIMENSIONS
3		LEFT AND RIGHT HAND SIDE CUTTING TOOLS DEPTH GAUGE	STEP SHAPING
4		ROUND-NOSE ROUGHING TOOL	FORM SHAPING

SCALE 1:1

MAT.: MILD STEEL

MOVEABLE JAW

(For bench vice)

No. 2.2.2 / 04

SHAPING II



DEVELOPMENT CELL FOR SKILLED LABOUR TRAINING

PAK-GERMAN TECHNICAL TRAINING PROGRAMME

MACHINIST

2 ∇ (\sim)

Tolerance $\pm 0,2$
unless otherwise stated

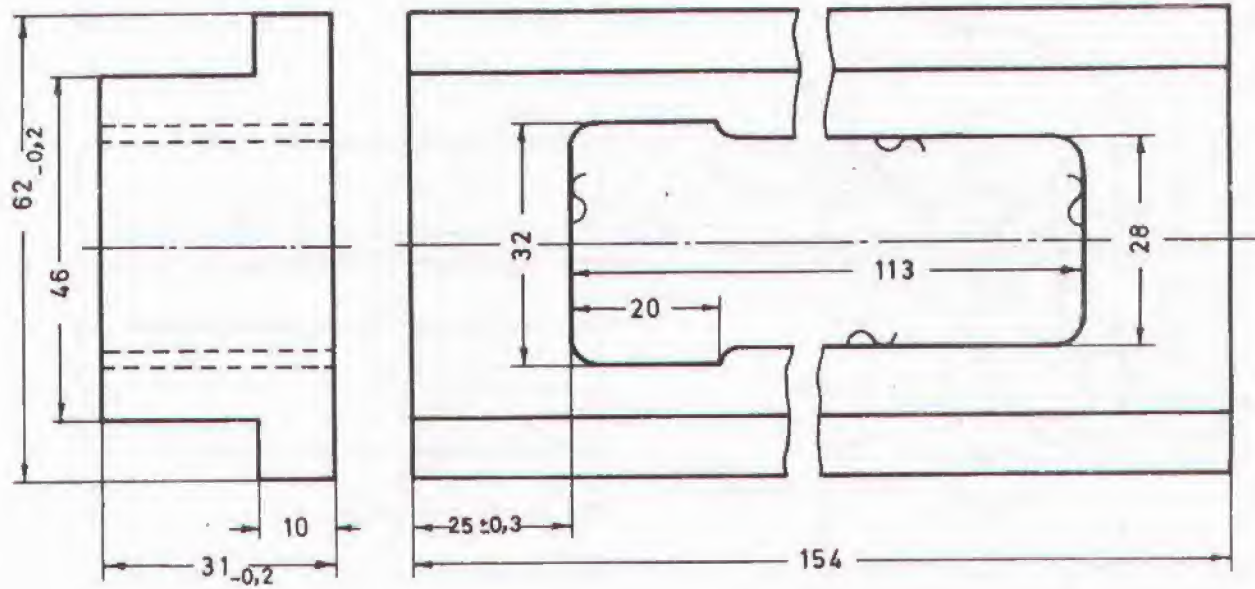

SEQUENCE OF OPERATIONS

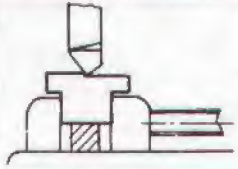
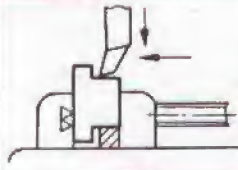
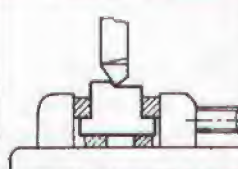
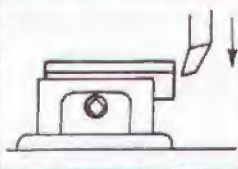
No.	Symbol	Tools	Descriptions
1		STRAIGHT LEFT HAND CUTTING TOOL PARALLELS	PLAN SHAPING OF REFERENCE SURFACE
2		LEFT HAND SIDE CUTTING TOOL	STEP SHAPING BOTH SIDES PARALLEL
3		STRAIGHT LEFT HAND CUTTING TOOL PARALLELS STRIPS	PARALLEL SHAPING USING STRIPS FOR PROPER CLAMPING
4		LEFT HAND SIDE CUTTING TOOL	VERTICAL SHAPING

SCALE 1:1

MAT.: CAST IRON

SLIDE BASE

(For machine vice)

No. 2.2.2 / 05

SHAPING II



DEVELOPMENT CELL FOR SKILLED LABOUR TRAINING

PAK-GERMAN TECHNICAL TRAINING PROGRAMME

MACHINIST



Tolerance ± 0.1
Unless otherwise stated

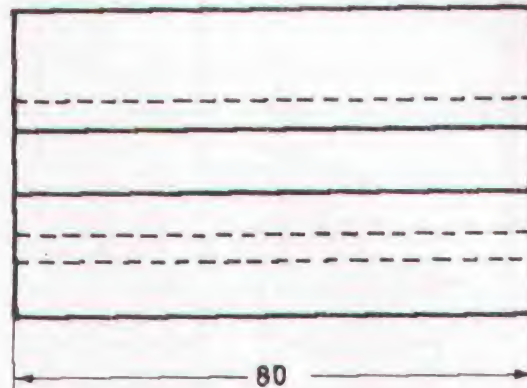
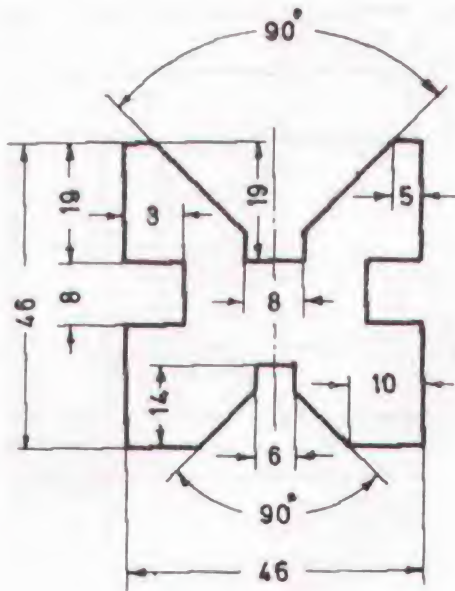

SEQUENCE OF OPERATIONS

No.	Symbol	Tools	Descriptions
1		STRAIGHT LEFT HAND CUTTING TOOL PARALLELS ROUND BAR	SQUARE AND PARALLEL SHAPING TO GIVEN DIMENSIONS
2		MARKING TOOLS ROUND-NOSE ROUGHING TOOL	MARKING ROUGHING OF V-GROOVE ACCORDING TO MARKING LINE
3		PARTING TOOL DEPTH GAUGE	GROOVING
4		SIDE CUTTING TOOL BEVEL PROTRACTOR	SETTING OF TOOL HEAD AT 45° SMOOTH SHAPING OF V-GROOVES

SCALE 1:1

MAT.: CARBON STEEL

V-BLOCK

No. 2.2.2/06

SHAPING II



DEVELOPMENT CELL FOR SKILLED LABOUR TRAINING

PAK-GERMAN TECHNICAL TRAINING PROGRAMME

MACHINIST



Tolerance $\pm 0,1$
unless otherwise stated.

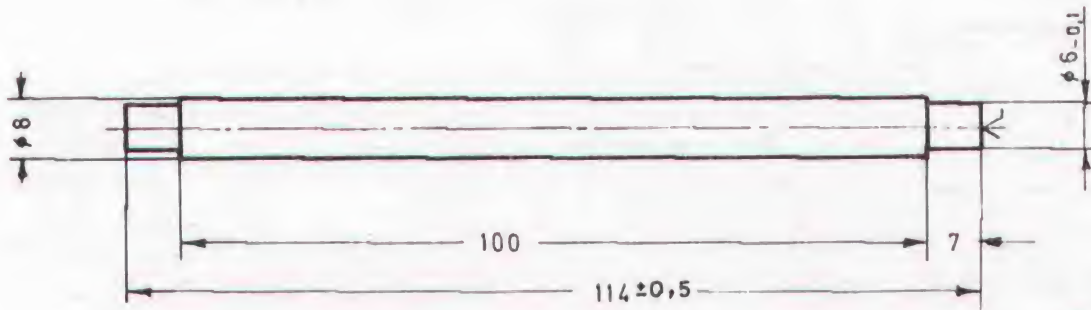

9

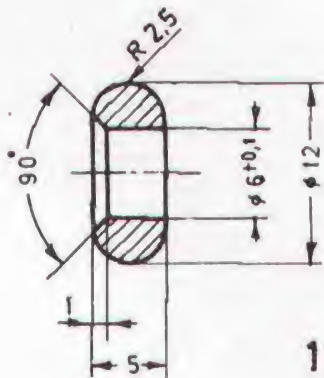

2 pieces

Scale 2:1

11

SEQUENCE OF OPERATIONS

No.	Symbol	Tools	Descriptions
1		3 - JAW CHUCK RIGHT HAND FACING TOOL CENTRE DRILL CENTRE POINT	LONGITUDINAL TURNING
2		COLLET CHUCK ϕ 8 MM RIGHT HAND FACING TOOL	CLAMPING IN COLLET CHUCK FACING SHOULDER TURNING
3		3 - JAW CHUCK RADIUS TOOL 2,5 MM PARTING TOOL DRILL ϕ 6 MM COUNTERSINK 90°	FORM TURNING DRILLING AND COUNTER- SINKING PARTING

SCALE 1:1, 2:1

TOGGLE

No. 2.2.3/01

MAT.: MILD-STEEL

(For bench vice)

TURNING II



DEVELOPMENT CELL FOR SKILLED LABOUR TRAINING

PAK-GERMAN TECHNICAL TRAINING PROGRAMME

MACHINIST



Tolerance $\pm 0,1$
unless otherwise stated

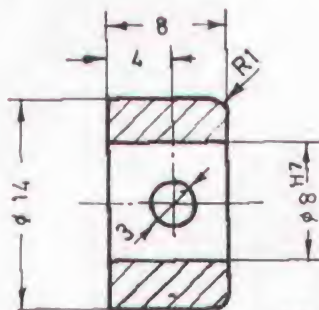
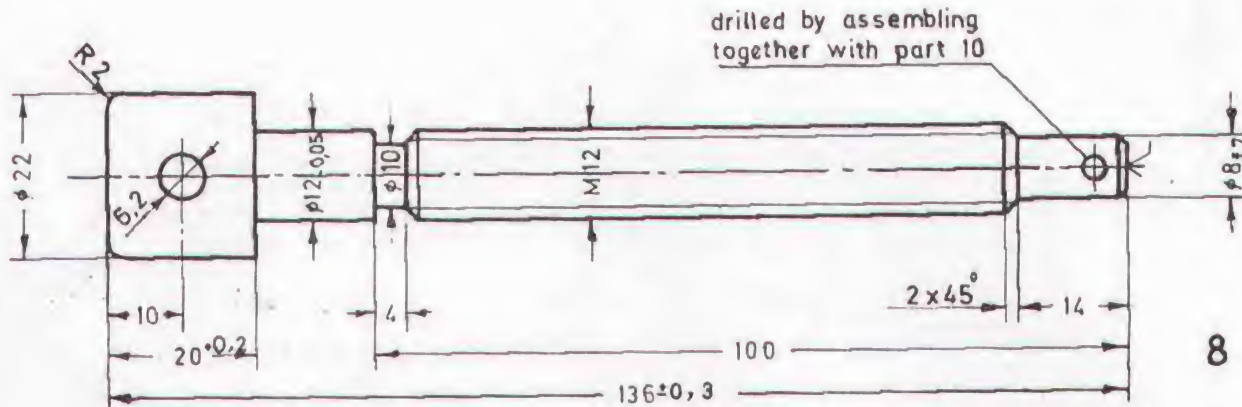

Scale 2:1

10

8 ^{H7}	+0,015 0
8 ^{f7}	-0,013 -0,028

SEQUENCE OF OPERATIONS

No.	Symbol	Tools	Descriptions
1		RIGHT AND LEFT HAND ROUGHING TOOLS RIGHT HAND FACING TOOL PARTING TOOL CENTRE DRILL MICROMETER	LONGITUDINAL TURNING TO MICROMETER SIZE NECKING
2		THREAD CUTTING TOOL CENTRE GAUGE 60°	SETTING OF THE MACHINE FOR THE REQUIRED PITCH SETTING OF THE THREAD - TOOL
3		THREAD RING GAUGE M12	CHECKING OF THE PITCH CUTTING OF THREAD CHECKING WITH THREAD RING GAUGE

SCALE 1:1, 2:1

MAT. : MILD STEEL

SPINDLE - & BUSH

(For bench vice)

No. 2.23 / 02

TURNING II



DEVELOPMENT CELL FOR SKILLED LABOUR TRAINING

PAK-GERMAN TECHNICAL TRAINING PROGRAMME

MACHINIST



Tolerance $\pm 0,1$
unless otherwise stated

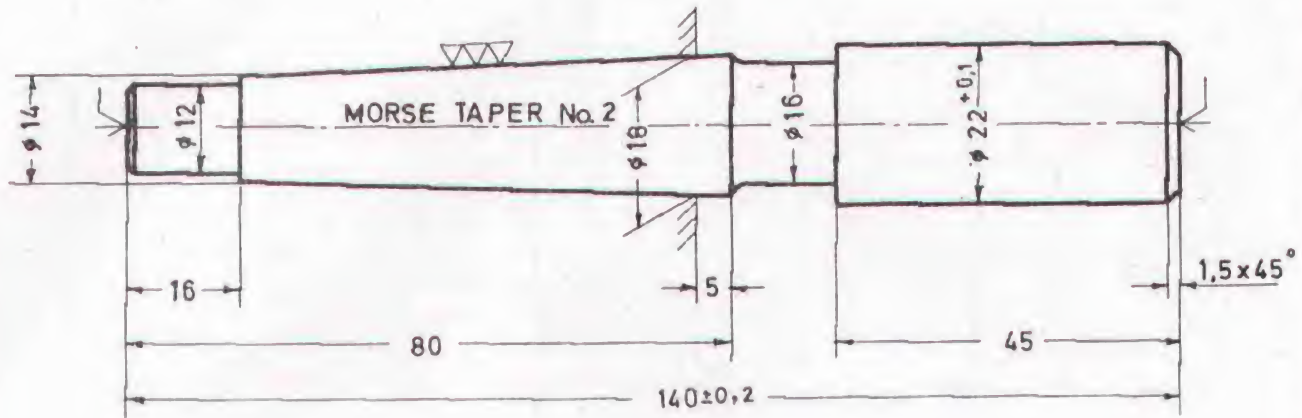

SEQUENCE OF OPERATIONS

No.	Symbol	Tools	Descriptions
1		3-JAW CHUCK RIGHT HAND ROUGHING TOOL RIGHT HAND FACING TOOL CENTRE DRILL	LONGITUDINAL ROUGH TURNING
2		ROUND NOSE SMOOTHING TOOL	SETTING OF COMPOUND REST TO REQUIRED ANGLE TAPER TURNING NECKING
3		TAPER GAUGE MORSE 2	CHECKING OF TAPER BY GAUGE
4		RIGHT HAND ROUGHING TOOL CENTRE DRILL HEADSTOCK TAPER SLEEVE	HOLDING OF THE WORKPIECE IN THE HEADSTOCK SPINDLE BY USING A SLEEVE AS AN ADAPTER. CENTERING, FACING TURNING OF $\phi 22$.

SCALE 1:1

MAT.: HIGH SPEED STEEL

CIRCULAR CUTTER

No. 2.2.3 / 03

TURNING II



DEVELOPMENT CELL FOR SKILLED LABOUR TRAINING

PAK-GERMAN TECHNICAL TRAINING PROGRAMME

MACHINIST

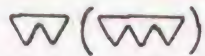

Tolerance $\pm 0,1$
unless otherwise stated

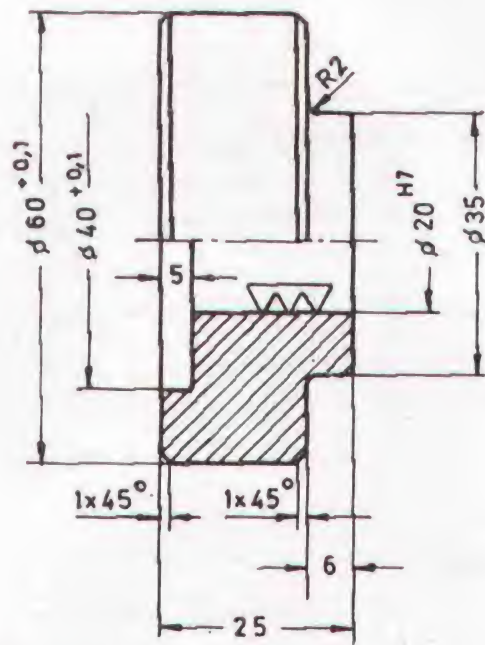

SEQUENCE OF OPERATIONS

20 H7	+0,021 0
-------	-------------

No.	Symbol	Tools	Descriptions
1		4-JAW INDEPENDENT CHUCK RIGHT-H. FACING TOOL DRILL $\phi 19,5$, REAMER 20^{H7} PLUG GAUGE 20^{H7}	FACING CENTERING DRILLING REAMING
2		GROUND BORING TOOL	TURNING OF RECESS $\phi 40$
3		RIGHT HAND FACING TOOL	RECHUCKING Rough Turning to $\phi 36 \times 55$ mm Length
4		MANDREL $\phi 20$ MM RIGHT HAND FACING TOOL RIGHT HAND ROUGHING TOOL	FITTING OF THE WORKPIECE ON A MANDREL. SETTING THE MANDREL AND LATHE DOG BETWEEN CENTRES SMOOTH TURNING

SCALE 1:1	GEAR-BLANK	No. 2.2.3 / 04
MAT. : CASE HARDENING STEEL		TURNING II
 DEVELOPMENT CELL FOR SKILLED LABOUR TRAINING PAK-GERMAN TECHNICAL TRAINING PROGRAMME		MACHINIST

6 ∇ (∇)

Tolerance $\pm 0,1$
unless otherwise stated

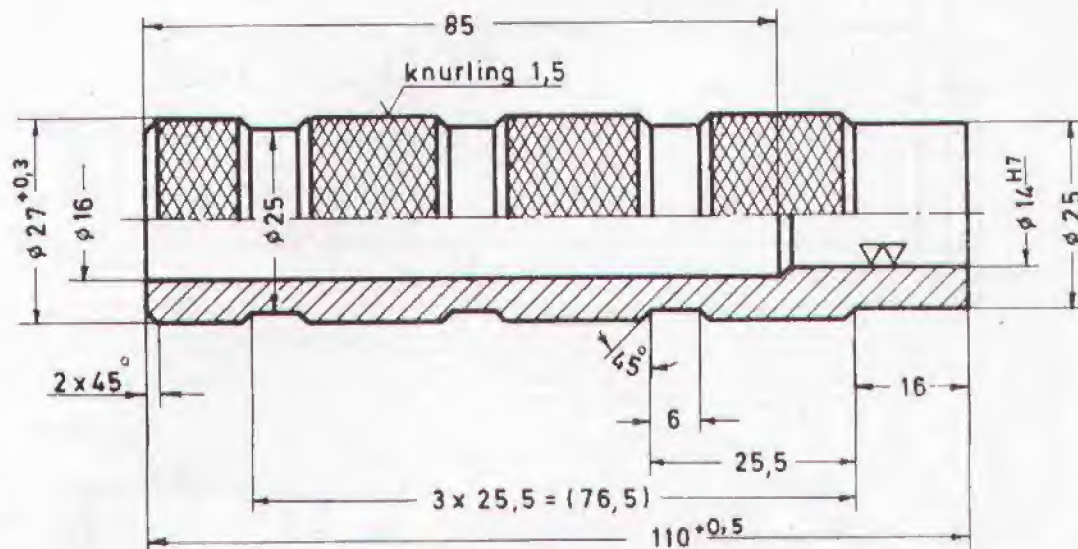

14 H7	+0,018 0
-------	-------------

SEQUENCE OF OPERATIONS

No.	Symbol	Tools	Descriptions
1		3-JAW CHUCK RIGHT HAND FACING TOOL RIGHT HAND ROUGHING TOOL CENTRE DRILL	FACING, CENTERING LONGITUDINAL TURNING APPROXIMATELY TO ϕ 28 (1 MM MACHINING ALLOWANCE FOR OPERATION NO. 3)
2		RIGHT HAND FACING TOOL RIGHT HAND ROUGHING TOOL CENTRE DRILL DRILL ϕ 13.5 REAMER 14H7	RECHUCKING, FACING CENTERING, DRILLING AND REAMING OF HOLE 14H7 TURNING OF ϕ 25
3		DRILL ϕ 16 KNURLING TOOL RIGHT HAND ROUGHING TOOL	CHUCKING IN 3-JAW CHUCK DRILLING OF HOLE ϕ 16 HOLDING BETW. CHUCK & TAIL- STOCK CENTRE, FINISHING ϕ 27 KNURLING GROOVING

SCALE 1:1

MAT.: MILD STEEL

HANDLE
for Mach. vice

No. 2.2.3/05

TURNING II



DEVELOPMENT CELL FOR SKILLED LABOUR TRAINING

PAK-GERMAN TECHNICAL TRAINING PROGRAMME

MACHINIST

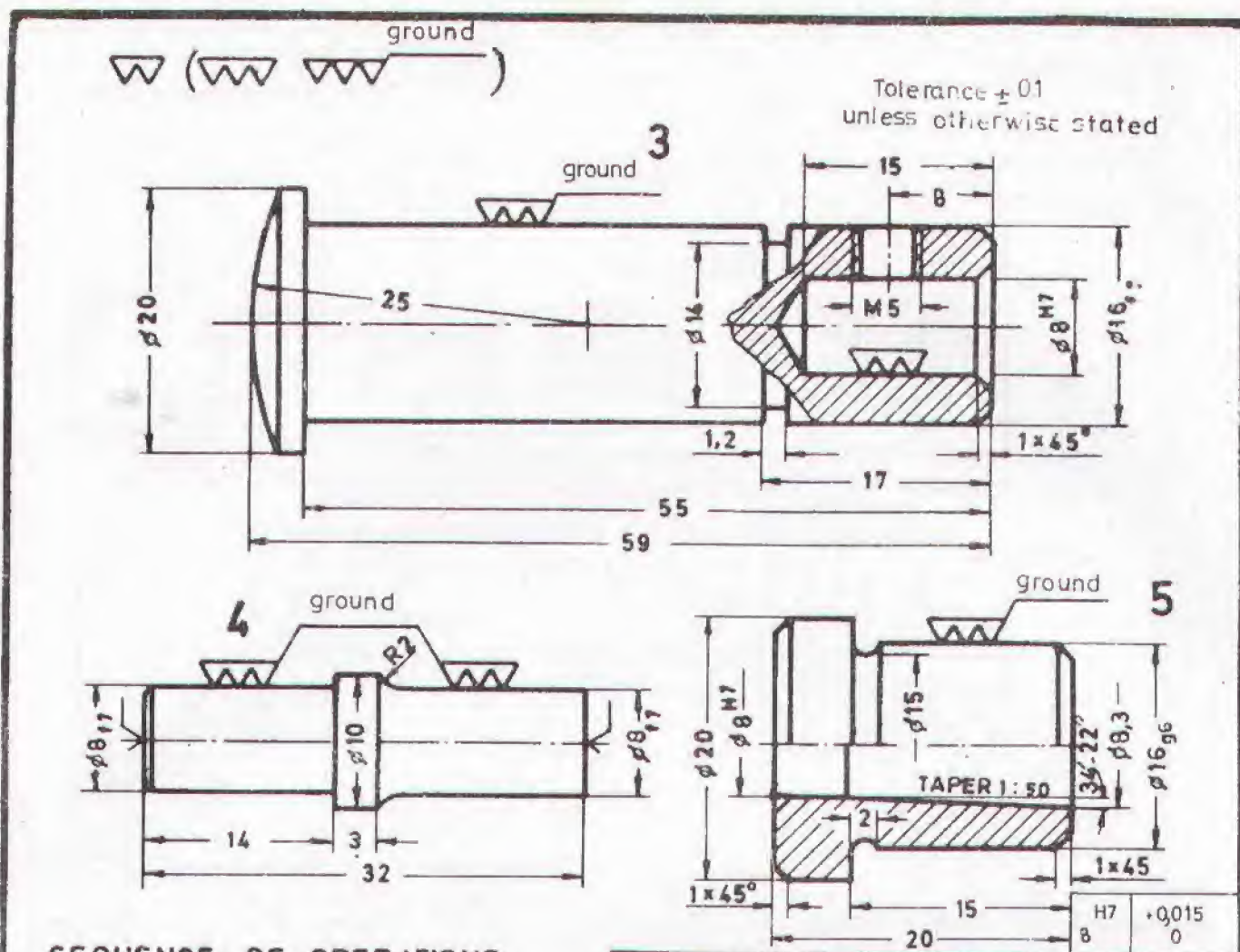

SEQUENCE OF OPERATIONS

ϕ_{17}	- 0.013 - 0.028	16_{f7}	- 0.016 - 0.034	16_{g6}	- 0.006 - 0.017
-------------	--------------------	-----------	--------------------	-----------	--------------------

No.	Symbol	Tools	Descriptions
1		R.-HAND FACING TOOL GROOVING TOOL R.-HAND ROUGHING TOOL DRILL 7,8 ϕ REAMER 8 ^{H7}	THE GUIDE BOLT AND THE BUSH ARE MACHINED OUT FROM ONE PIECE OF RAW MATERIAL. TURNING TO MICROMETER SIZE. GROOVING, DRILLING AND REAMING PART NO. 3
2		RADIUS TOOL R1 PARTING TOOL TAPER REAMER 1:50 DRILL 7,8 ϕ	RECHUCKING IN COLLET CHUCK TURNING OF $\phi 16_{g6}$ MIND GRINDING ALLOWANCE DRILLING, REAMING OF TAPER. PARTING
3		RADIUS TOOL R25	FACING RADIUS TURNING

SCALE 2:1	GUIDE BOLT, PUNCH AND BUSH (For punching device)	No. 2.2.3/06
MAT: LOW CARBON STEEL		TURNING II
 DEVELOPMENT CELL FOR SKILLED LABOUR TRAINING PAK-GERMAN TECHNICAL TRAINING PROGRAMME		MACHINIST



Tolerance $\pm 0,1$

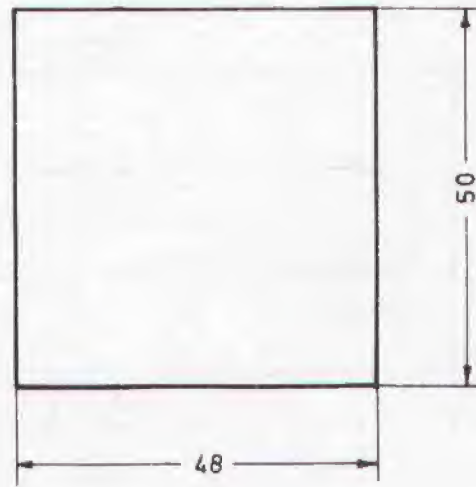

SEQUENCE OF OPERATIONS

No.	Symbol	Tools	Descriptions
1		MACHINE VICE PARALLEL BARS ROUND BAR SHELL END MILL CUTTER	SET THE WORKPIECE ON PARALLELS, USE A ROUND ROD BETWEEN THE WORK AND MOVABLE JAW OF THE VICE FACING OF SURFACE NO. I.
2		MACHINE VICE PARALLEL BARS ROUND BAR SHELL END MILL CUTTER	PLACE SURFACE NO. I AGAINST THE SOLID JAW USE THE ROUND ROD. FACING OF SURFACE NO. II.
3		MACHINE VICE PARALLEL BARS ROUND BAR SHELL END MILL CUTTER	REPEAT THE OPERATIONS TO FACE SURFACE NO. III AND IV.
4		MACHINE VICE PARALLEL BARS TRY SQUARE SHELL END MILL CUTTER	CHECK THE RIGHT ANGLE BY USING A TRY SQUARE FOR MILLING SURFACE NO. V AND VI.

SCALE 1:1

MAT.: MILD STEEL

CLAMPING PIECE (VICE)

No. 2.2.4 / 1

MILLING I



DEVELOPMENT CELL FOR SKILLED LABOUR TRAINING

PAK-GERMAN TECHNICAL TRAINING PROGRAMME

MACHINIST



Tolerance ± 0.1
unless otherwise stated

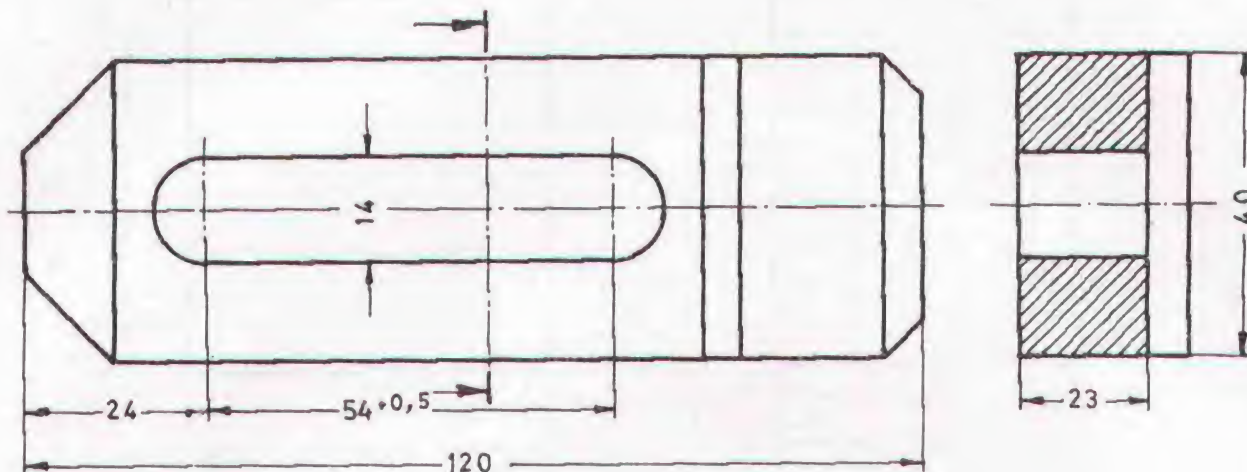

SEQUENCE OF OPERATIONS

No.	Symbol	Tools	Descriptions
1		MACHINE VICE DIAL TEST INDICATOR WITH STAND	ALIGNING OF THE SOLID VICE JAW USING A DIAL TEST INDICATOR
2		PARALLEL BARS STRAIGHT-OR TAPER- SHANK MULTIPLE-FLUTE END MILL CUTTER	MOUNTING OF THE VERTICAL HEAD. CLAMPING OF THE CUTTER AND WORKPIECE. LOCATING THE CUTTER TO THE CENTRE OF THE WORKPIECE.
3			ADJUSTING OF THE STOPS ACCORDING TO THE LENGTH OF THE SLOT. MILLING OF THE KEYSLOT.

SCALE 1:1

MAT.: MILD STEEL

from Turner / Shop. II

CLAMP

No. 2.2.4 / 2

MILLING I



DEVELOPMENT CELL FOR SKILLED LABOUR TRAINING

PAK-GERMAN TECHNICAL TRAINING PROGRAMME

MACHINIST



Tolerance ± 0.1

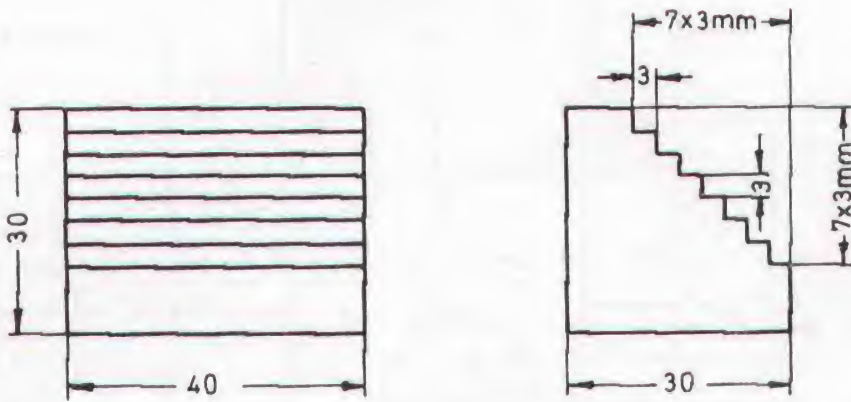

SEQUENCE OF OPERATIONS

No.	Symbol	Tools	Descriptions
1		MACHINE VICE PARALLEL BARS SHELL END MILL CUTTER	MILLING OF THE DIMENSIONS 30x30x40 IN THE SAME WAY AS DONE IN EX. 1
2		BEVEL PROTRACTOR MARKING TOOLS SHELL END MILL CUTTER	MARKING OF THE 45° LINE ROUGH MILLING TO THE REQUIRED ANGLE
3		MACHINE VICE PARALLEL BARS SHELL END MILL CUTTER	RECLAMPING OF THE WORKPIECE MILLING OF THE STEPS BY DISPLACING THE MACHINE TABLE IN VERTICAL AND HORIZONTAL DIRECTION BY 3 MM FOR EACH STEP.

SCALE 1:1

MAT.: MILD STEEL

STEP BLOCK

No. 2.2.4 / 3

MILLING I



DEVELOPMENT CELL FOR SKILLED LABOUR TRAINING

PAK-GERMAN TECHNICAL TRAINING PROGRAMME

MACHINIST

1 W

Tolerance $\pm 0,1$
unless otherwise stated

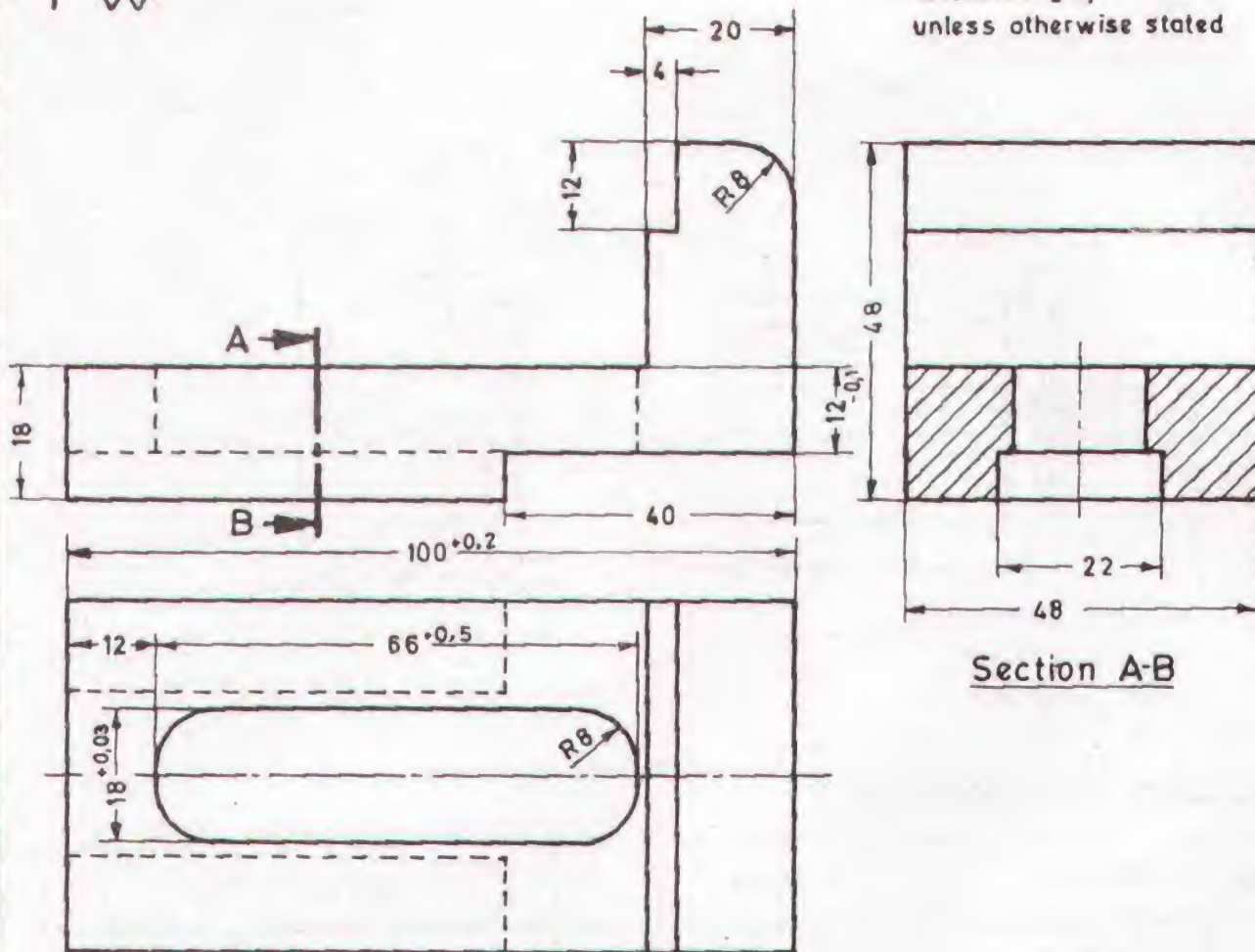

SEQUENCE OF OPERATIONS

No.	Symbol	Tools	Descriptions
1		MACHINE VICE PARALLEL BARS SHELL END MILL CUTTER DEPTH GAUGE	FACING BOTH SIDES TO THE LENGTH OF 100 MM. MILLING OF THICKNESS 18 AND DIMENSION 20 MM MILLING OF STEP 12x4 MM
2		MACHINE VICE PARALLEL BARS STRAIGHT OR TAPER SHANK END MILL CUTTER	MILLING OF KEYSLOT AND STEP 40x6 MM MAKE SURE THAT THE SADDLE OF THE MACHINE IS FIXED DURING MILLING OPERATION
3		MACHINE VICE PARALLEL BARS SIDE MILLING CUTTER DEPTH GAUGE	MILLING OF THE SLOT 22x6 MM

SCALE 1:1

FIXED JAW

No. 2.2.4/4

MAT.: MILD STEEL

from Mach./Shap. II

(For bench vice)

MILLING I



DEVELOPMENT CELL FOR SKILLED LABOUR TRAINING

PAK-GERMAN TECHNICAL TRAINING PROGRAMME

MACHIINIST

2 

Tolerance $\pm 0,1$
unless otherwise stated

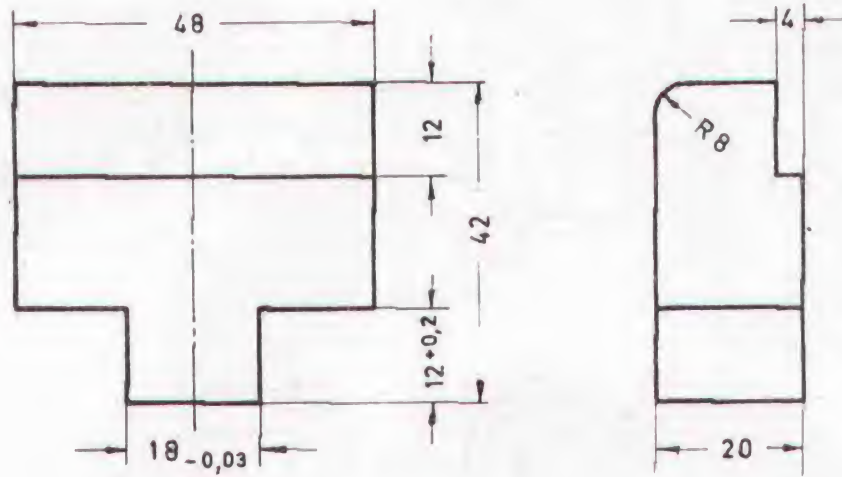

مزید کتب پڑھنے کے لئے آج ہی وزٹ کریں: www.iqbalkalmati.blogspot.com

SEQUENCE OF OPERATIONS

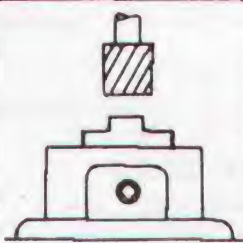
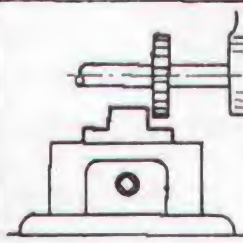
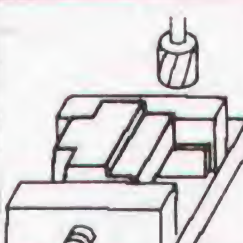
No.	Symbol	Tools	Descriptions
1		MACHINE VICE PARALLEL BARS SHELL END MILL CUTTER	PLANE MILLING OF THE BASE SURFACE
2		STRAIGHT-TOOTH SIDE MILLING CUTTER MICROMETER 0 - 25 MM DEPTH GAUGE	MOUNTING OF THE SIDE MILLING CUTTER MILLING OF THE DIMENSION $18_{-0,03}$ AND DEPTH $12^{+0,2}$
3		PARALLEL BARS SHELL END MILL CUTTER	RECLAMPING OF THE WORKPIECE MILLING OF THE THICKNESS 20 AND STEP 4×12 MM

SCALE 1:1

MAT.: MILD STEEL

MOVEABLE JAW

from Mach. / Shap. II

(For bench vice)

No. 2.2.4/5

MILLING I



DEVELOPMENT CELL FOR SKILLED LABOUR TRAINING

PAK-GERMAN TECHNICAL TRAINING PROGRAMME

MACHINIST



Tolerance $\pm 0,1$

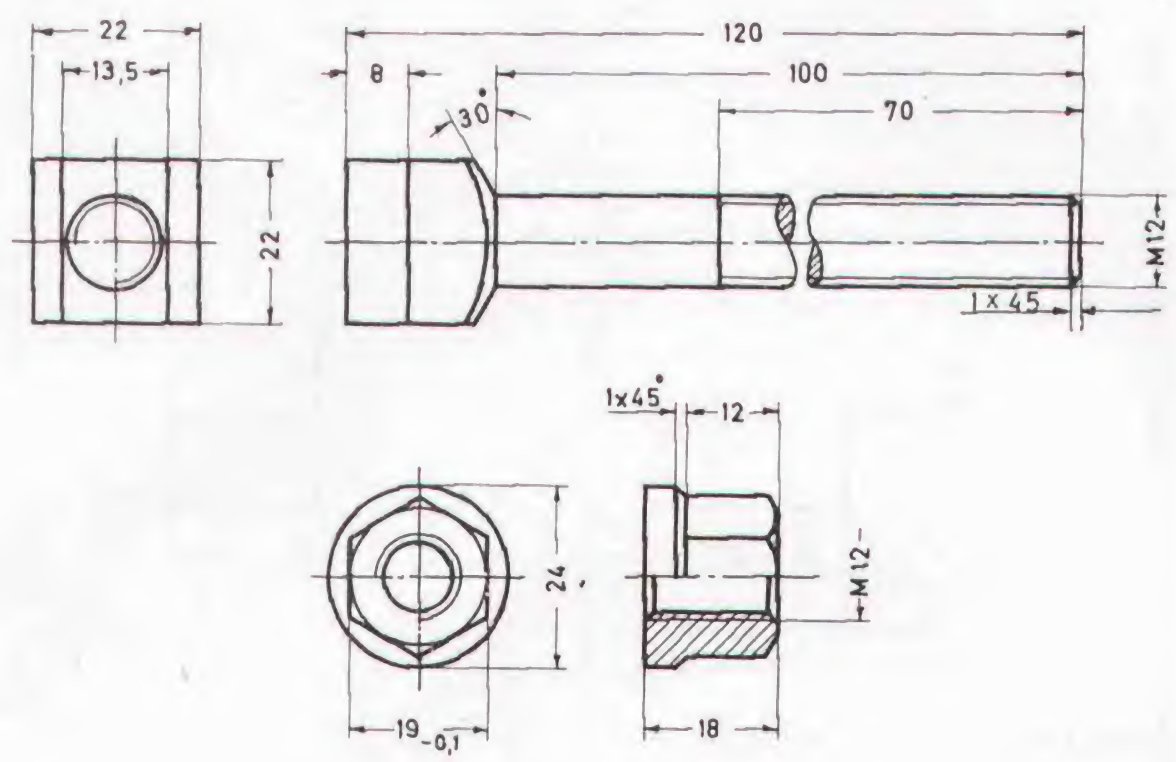

SEQUENCE OF OPERATIONS

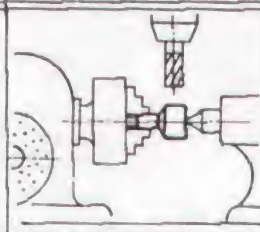
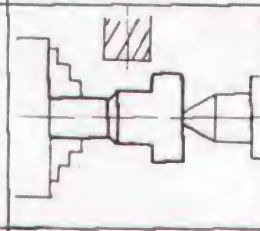
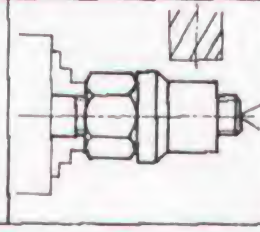
No.	Symbol	Tools	Descriptions
1		DIVIDING HEAD AND TAIL STOCK STRAIGHT OR TAPER SHANK END MILL CUTTER	MOUNTING OF THE DIVIDING HEAD AND TAIL STOCK. MILLING OF THE SQUARE 22MM
2		DIVIDING HEAD AND TAIL STOCK STRAIGHT OR TAPER SHANK END MILL CUTTER	MILLING OF THE DIMENSION 13,5 MIND THE CENTRE POSITION
3		THREADED MANDREL WITH HEX. NUT M12 STRAIGHT OR TAPER SHANK END MILL CUTTER	HOLDING THE NUT ON A THREADED MANDREL WITH A COUNTERNUT MILLING OF THE HEXAGON 19 _{-0,1}

SCALE 1:1	BOLT AND NUT <small>(from Turner / Turn II)</small>	No. 2.2.4 / 6
MAT.: MILD STEEL		MILLING I
 DEVELOPMENT CELL FOR SKILLED LABOUR TRAINING PAK-GERMAN TECHNICAL TRAINING PROGRAMME		MACHINIST

1 

Tolerance $\pm 0,1$
unless otherwise stated

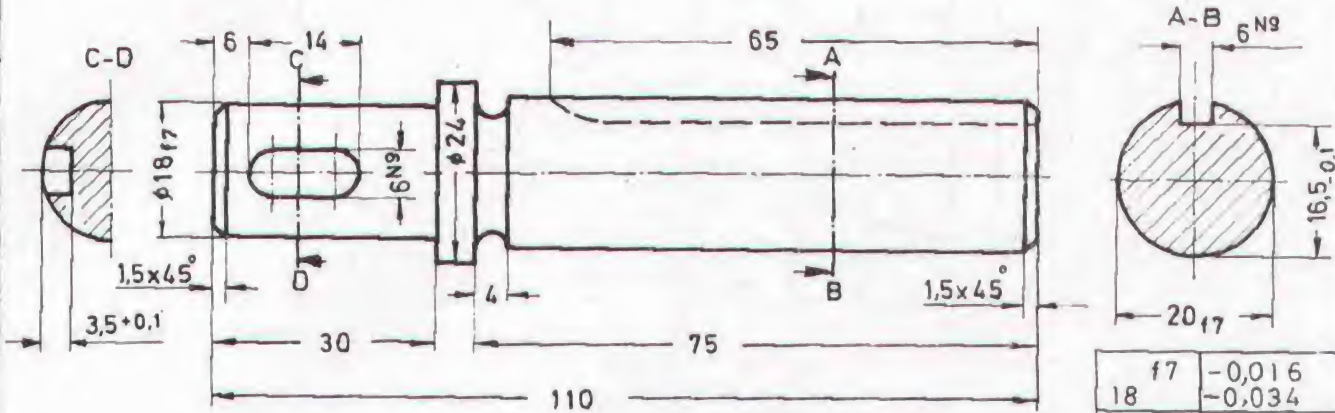

$f7$	-0,016
18	-0,034
$f7$	-0,020
20	-0,041
$6N9$	0
	-0,03

SEQUENCE OF OPERATIONS

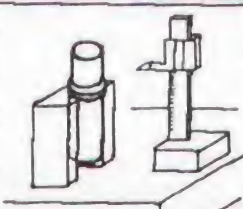
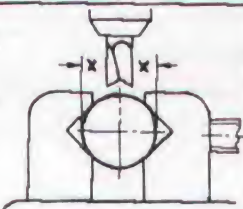
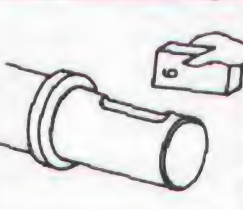
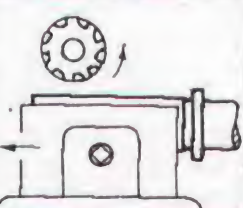
No.	Symbol	Tools	Descriptions
1		MARKING PLATE HEIGHT GAUGE V-BLOCK	MARKING THE POSITION AND LENGTH OF THE KEYWAY
2		MACHINE VICE WITH V-SHAPE JAWS TWO-LIP END MILL CUTTER DEPTH GAUGE	ALIGNING OF THE MACH. VICE AND CLAMPING OF THE SHAFT LOCATING THE CUTTER TO THE CENTRE OF WORKPIECE SETTING OF THE STOPS MILLING OF THE KEYWAY
3		LIMIT GAUGE	CHECKING OF THE WIDTH 6N9 WITH A LIMIT GAUGE
4		PLAIN MILLING CUTTER 6 MM WIDTH	MOUNTING OF THE PLAIN MILLING CUTTER LOCATING THE CUTTER TO THE CENTRE OF WORKPIECE MILLING OF THE LONG KEYWAY

SCALE 1:1

MAT.: MILD STEEL

from Turner / Turn. II

SHAFT

No. 2.2.4/7

MILLING I



DEVELOPMENT CELL FOR SKILLED LABOUR TRAINING



PAK-GERMAN TECHNICAL TRAINING PROGRAMME

MACHINIST

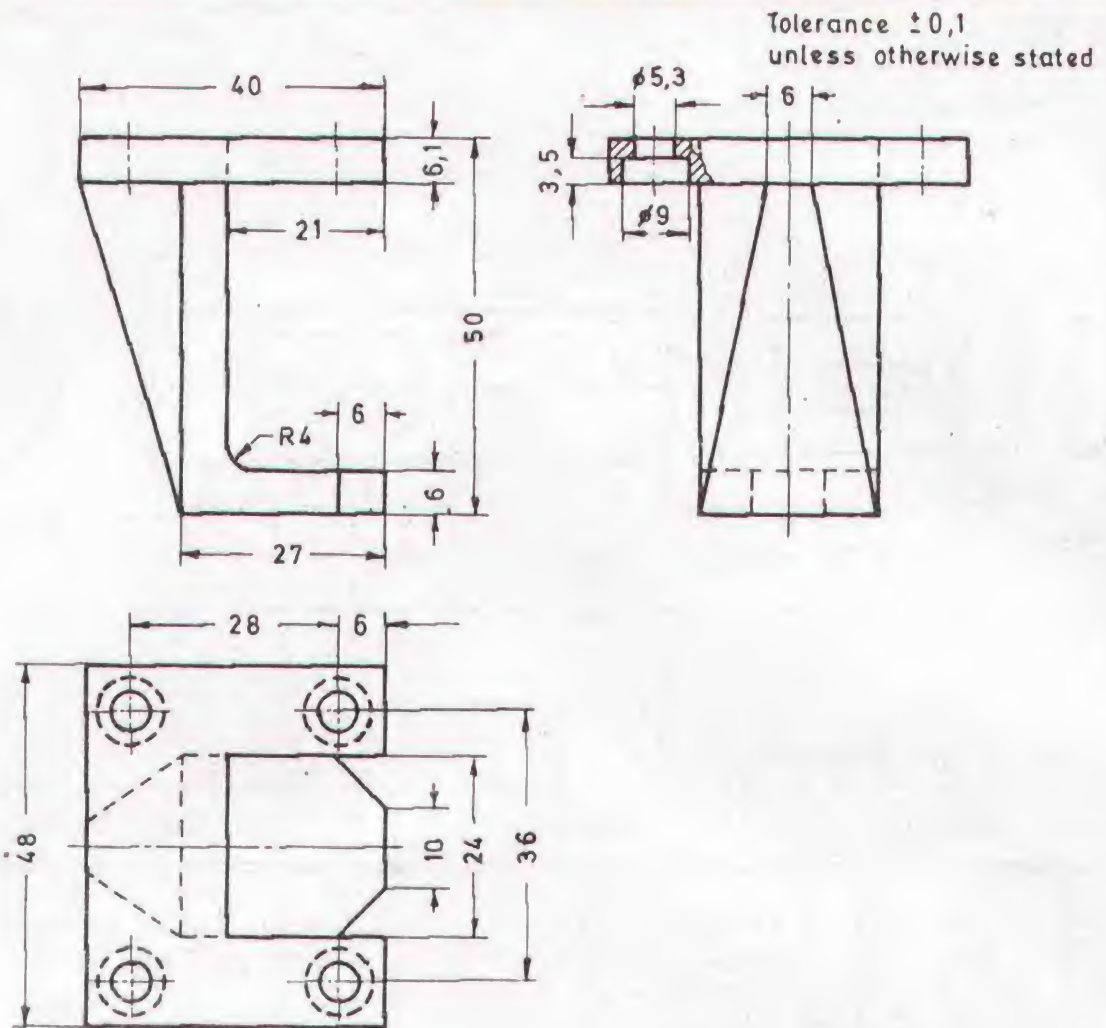
3 

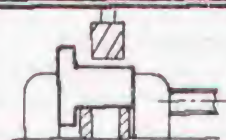
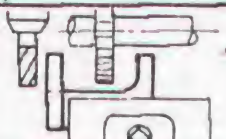

SEQUENCE OF OPERATIONS

No	Symbol	Tools	Descriptions
1		MACHINE VICE PARALLEL BARS SHELL END MILL CUTTER	MILLING OF THE T-SHAPE DIMENSION 24
2		MARKING TOOLS TWIST DRILL 8 MM SIDE MILLING CUTTER SHANK END MILL CUTTER	MARKING AND DRILLING OF THE HOLE FOR THE RADIUS 4 MILLING OF THE RECESSES
3		BEVEL PROTRACTOR SHELL END MILL CUTTER	MARKING OF THE INCLINA- TIONS CLAMPING OF THE WORKPIECE SO THAT THE MARKING LINES ARE PARALLEL WITH THE JAW
4		SHELL END MILL CUTTER	RECLAMPING OF WORKPIECE SO THAT THE END POINTS OF THE BACKSIDE INCLINATION ARE IN LEVEL

SCALE 1:1

MAT.: MILD STEEL

from Mach/Mill. I

CLAMP PIECE

(For bench vice)

No. 2.2.4 / 8

MILLING I



DEVELOPMENT CELL FOR SKILLED LABOUR TRAINING

PAK-GERMAN TECHNICAL TRAINING PROGRAMME

MACHINIST

3 

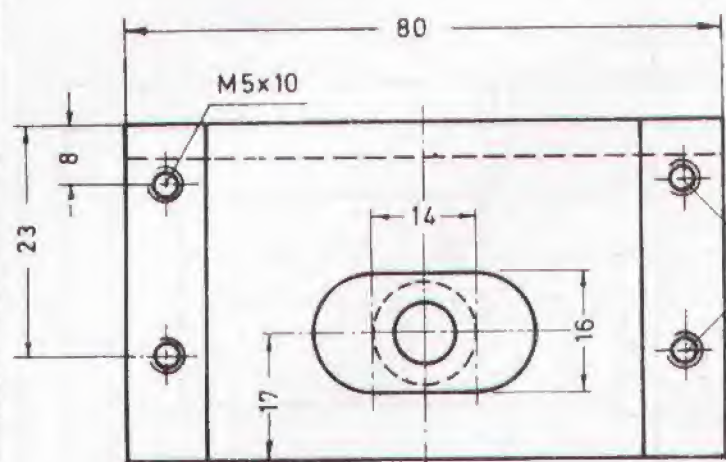

Tolerance ± 0.1
unless otherwise stated

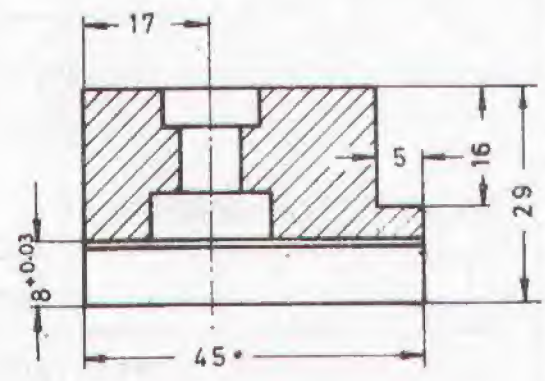
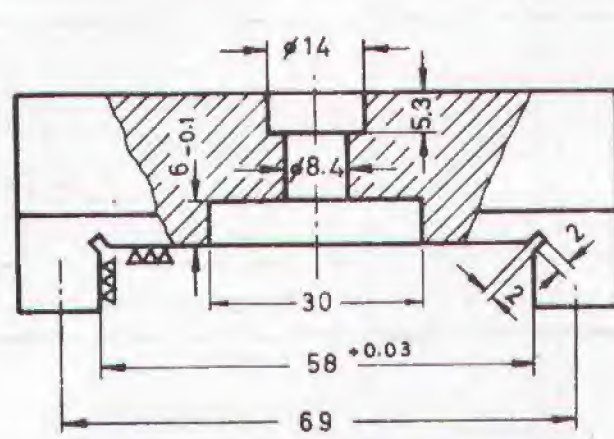

Holes for M5 drilled together with Parts No. 8 while assembling

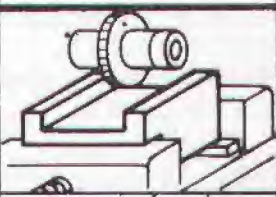

SEQUENCE OF OPERATIONS

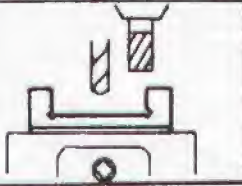
No.	Symbol	Tools	Descriptions
1		MACHINE VICE PARALLEL BARS SIDE MILLING CUTTER LIMIT GAUGE SET DEPTH MICROMETER	MILLING OF THE SLOT $58^{+0,03} \times 8^{+0,03}$
2		PLAIN METAL SLITTING SAW 2 MM WIDTH	MOUNTING OF THE VERTICAL HEAD AND SETTING TO AN ANGLE OF 45° CUTTING FREE OF THE EDGES
3		CENTRE DRILL, TWIST DRILL $\phi 8,4$ MM COUNTER BORE 14 MM SHANK END MILL CUTTER	MARKING AND DRILLING OF THE HOLE $\phi 8,4$ MILLING OF KEYSLOT RECLAMPING AND COUNTER- BORING

SCALE 1:1

MOVEABLE JAW

No. 2 2,4 / 9

MAT.: CAST IRON

from Turn/Shop. II

(For machine vice)

MILLING I



DEVELOPMENT CELL FOR SKILLED LABOUR TRAINING

PAK-GERMAN TECHNICAL TRAINING PROGRAMME

MACHINIST

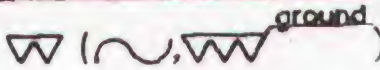
2 

Tolerance $\pm 0,1$
unless otherwise stated

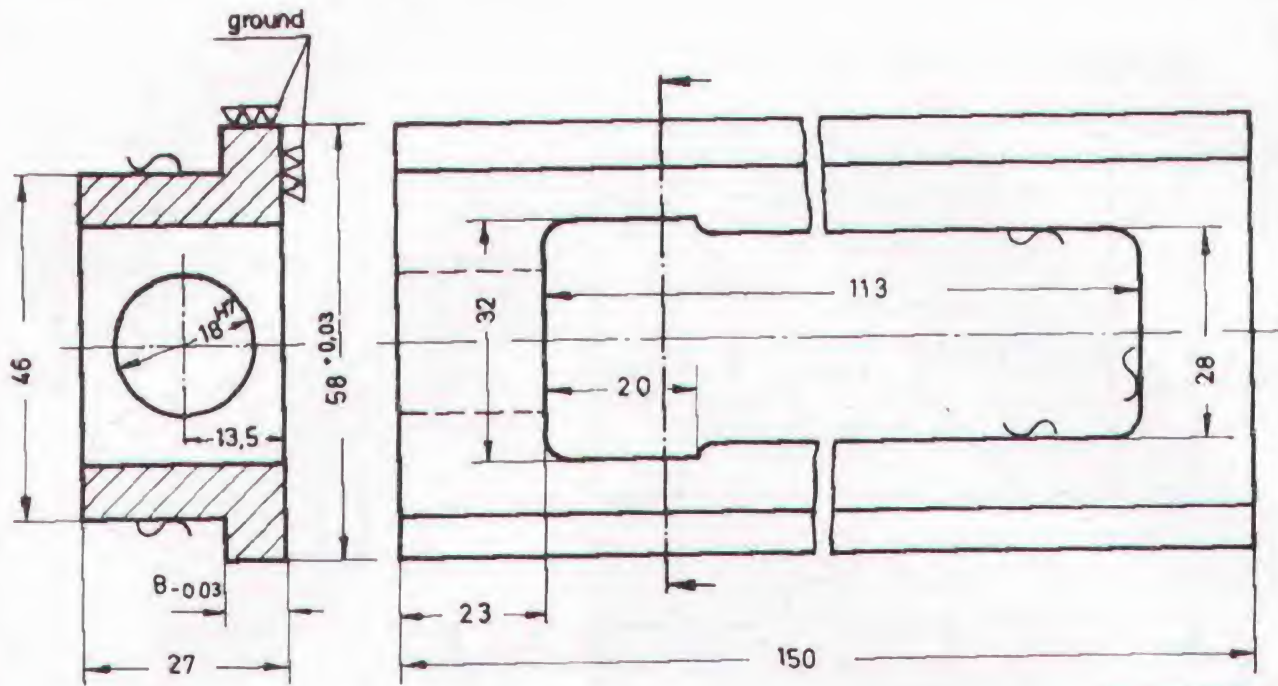

18^{H7} $\begin{matrix} +0,018 \\ 0 \end{matrix}$

SEQUENCE OF OPERATIONS

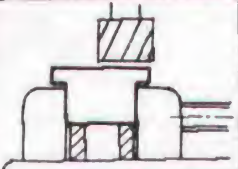
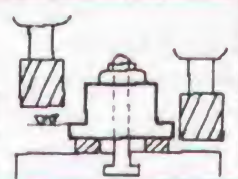
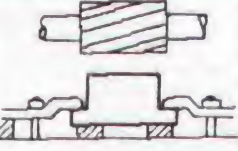
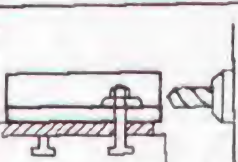
No.	Symbol	Tools	Descriptions
1		MACHINE VICE PARALLEL BARS SHELL END MILL CUTTER	MILLING OF REFERENCE SURFACE
2		PARALLEL BARS CLAMPS WITH SCREWS SHELL END MILL CUTTER	CLAMPING ON THE MACH.-TABLE BY THE HELP OF CLAMPS MILLING OF WIDTH 58 AND THICKNESS 8 MIND THE GRINDING ALLOWANCE
3		COARSE TOOTH HELICAL CUTTER	RESETTING OF THE CLAMPS MILLING OF THICKNESS 27 MIND THE GRINDING ALLOWANCE
4		CENTRE DRILL TWIST DRILL 17,5 MM MACH. REAMER 18^{H7} DIAL TEST INDICATOR	CLAMPING OF THE WORKPIECE PARALLEL TO THE ARBOR FACING OF THE LENGTH DRILLING AND REAMING OF THE HOLE 18^{H7}

SCALE 1:1

MAT.: CAST IRON

from Mach/Shap.II

SLIDE

(For machine vice)

No. 2.2.4 / 10

MILLING I



DEVELOPMENT CELL FOR SKILLED LABOUR TRAINING

PAK-GERMAN TECHNICAL TRAINING PROGRAMME

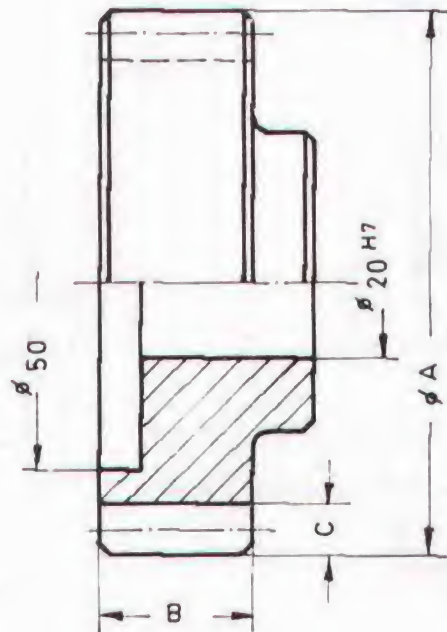

MACHINIST



20 ^{H7}	+0.021 0
------------------	-------------

A	B	C	Module	No. of teeth
78mm	20mm	6.6mm	3	24
60mm	19mm	6.6mm	3	18

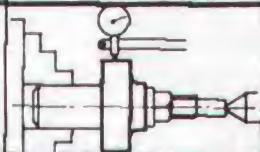
SEQUENCE OF OPERATIONS

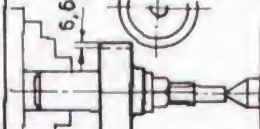
No.	Symbol	Tools	Descriptions
1		DIVIDING HEAD AND TAIL STOCK MILLING MANDREL DIAL TEST INDICATOR	MOUNTING OF DIVIDING HEAD CLAMPING OF THE GEAR BLANK CHECKING OF TRUE RUNNING
2		SPUR GEAR CUTTER MODUL 3 NO. 3 OR 4 ACCORDING TO THE NUMBER OF TEETH	LOCATING THE GEAR CUTTER TO THE CENTRE OF THE GEAR BLANK CALCULATION OF INDEX STEP
3		TOOTH FLANK MICROMETER	SETTING OF THE REQUIRED INDEX PLATE MILLING OF THE TEETH CHECKING OF PROPER DIVIDING

SCALE 1:1

MAT.. CASE HARDEN
ING STEEL

GEAR

From Machinist and T.&D. Maker /Turning II

No. 2.2.4 / 11

MILLING I



DEVELOPMENT CELL FOR SKILLED LABOUR TRAINING

PAK-GERMAN TECHNICAL TRAINING PROGRAMME

MACHINIST

~ (W)

Tolerance ± 0.1
unless otherwise stated

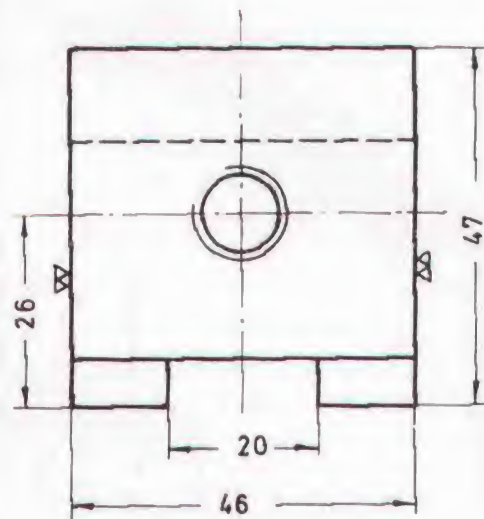
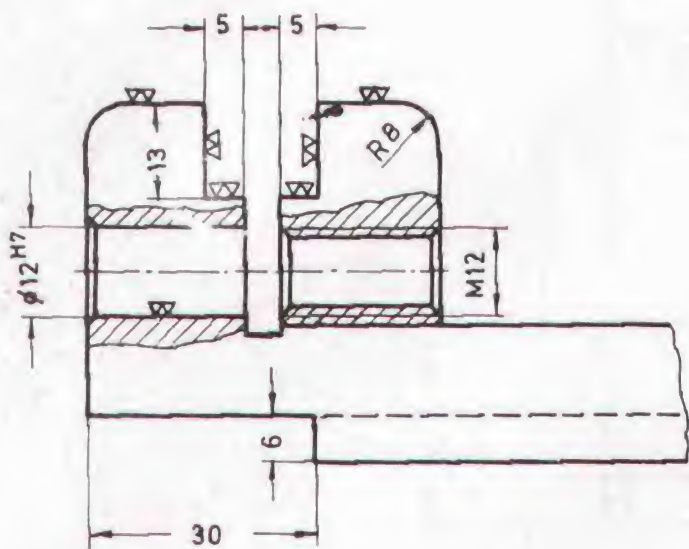

SEQUENCE OF OPERATIONS

12 H7 +0.018
0

No.	Symbol	Tools	Descriptions
1			SCREW PART I AND II TOGETHER, CLAMP BETWEEN THE SLIDE AND THE SLIDE-PLATE, PAPER SHIM AS SHOWN.
2		SIDE MILLING CUTTER DRILL $\phi 9.8$ $\phi 11.9$ TO REAM THE HOLE	FINISH THE STEPS START DRILLING WITH A $\phi 9.8$ MM DRILL. PART I DRILL LATER WITH $\phi 11.9$ MM.
3		SHELL END MILL CUTTER	FINISH TOP AND THE REMAINING SURFACES.

SCALE 1:1

MAT. MILD STEEL

FIXED & MOVEABLE JAW

From 2.2.414&5

(For bench vice)

No. 2.2.4/12





MILLING I



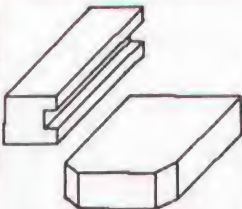

DEVELOPMENT CELL FOR SKILLED LABOUR TRAINING

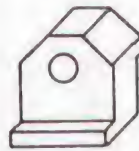
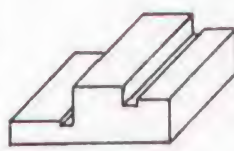

PAK-GERMAN TECHNICAL TRAINING PROGRAMME

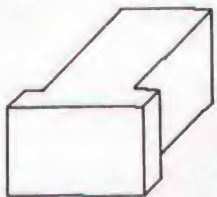

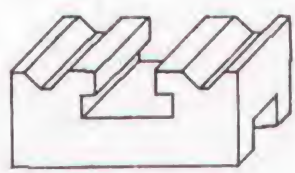
MACHINIST

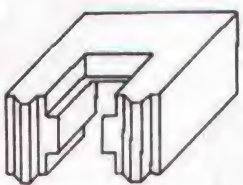
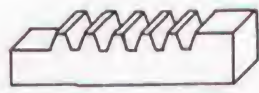
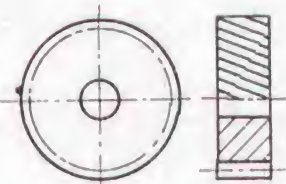
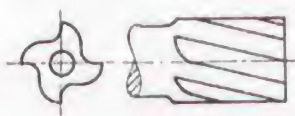
SHAPING 3.2.1				
				
Parallel & square shap. 1/2 → 3.2.2/4	Parallel & square shap. 3 → 3.2.4/2	Form shaping 4	Step shaping, Grooving 5 → 3.2.4/3	Slotting 2.2.4/11 → 6

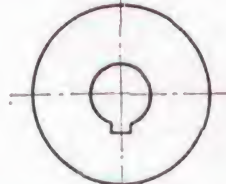
MILLING 3.2.2			
			
Step milling 1 3.4.4/1	Slotting with side mill 2 3.3.4/2	Form milling 3 3.4.4/4	V-Groove & T-Slot milling 3.2.1/1 4 3.4.4/1

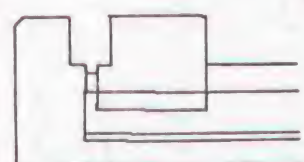
			
Form milling 3.2.1/2 → 5 → 3.4.4/1	Rack milling 6	Helical gear milling 3.1.1/3 3.4.1/4 → 7	Helical flute milling 3.3.1/5 → 8

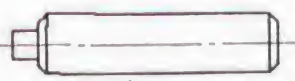
			
Work with rotary table 3.2.4/2 → 9	Keyway slotting 2.1.2/6 → 10	Radii milling 11	Parallel milling 3.3.4/1 → 12

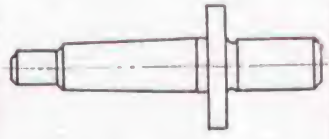
CIRCULAR GRINDING 3.2.3			
			
Cylindrical grinding 1	Cylindrical grinding 2.1.2/1 → 2	Shoulder grinding 2.1.2/11 → 3 → 3.4.4/2	Taper grinding 2.1.2/10 → 4

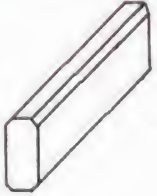
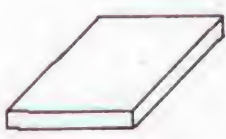
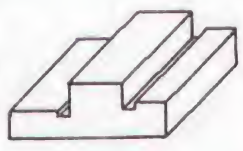
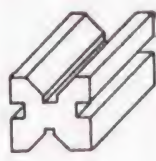
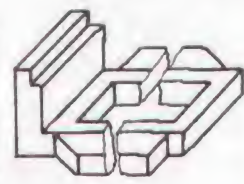
SURFACE GRINDING 3.2.4				
				
2.1.3/1 → 1	3.2.1/3 → 2 → 3.2.2/9	3.2.1/5 → 3	2.2.2/6 → 4	3.3.4/1 → 5

TRADE TRAINING	LAYOUT	No. 3.2.1 No. 3.2.2 No. 3.2.3 No. 3.2.4
----------------	--------	--



DEVELOPMENT CELL FOR SKILLED LABOUR TRAINING

PAK-GERMAN TECHNICAL TRAINING PROGRAMME

MACHINIST

MATERIAL REQUIRED

TRADE TRAINING for Machinist

Shaping No. 3.2.1	Exercise No. (Length given in millimeter)					Length per trainee	Total length for a batch of 16 trainees
	1	2	3	4	5		
M/S Square 50 mm (2")	115			25		140 mm	2,4 meter
Cast iron according to pattern	X						
M/S Flat 90 x 10 mm (4" x 3/8)			110			110 mm	1,9 meter
M/S Flat 100 x 20 mm (4" x 3/4)				65		65 mm	1,2 meter
Milling No. 3.2.2	Exercise No. (Length given in millimeter)					Length per trainee	Total length for a batch of 16 trainees
	1	2	3	6	11		
M/S Square 50 mm (2")	70					70 mm	1,2 meter
M/S Square 25 mm (1")		60		115		175 mm	3,0 meter
Low carbon steel 30 x 20 mm (1 1/4" x 3/4")			75			75 mm	1,3 meter
Low carbon steel 35 x 10 mm (1 1/4" x 3/8")					105	105 mm	1,8 meter
Circular Gr. No. 3.2.3	Exercise No. (Length given in millimeter)					Length per trainee	Total length for a batch of 16 trainees
	1						
M/S Round 25 mm (1")	135					135 mm	2,3 meter

For details please see Layout



DEVELOPMENT CELL FOR SKILLED LABOUR TRAINING

PAK-GERMAN TECHNICAL TRAINING PROGRAMME

Machinist

2 

Tolerance ± 0.1
unless otherwise stated

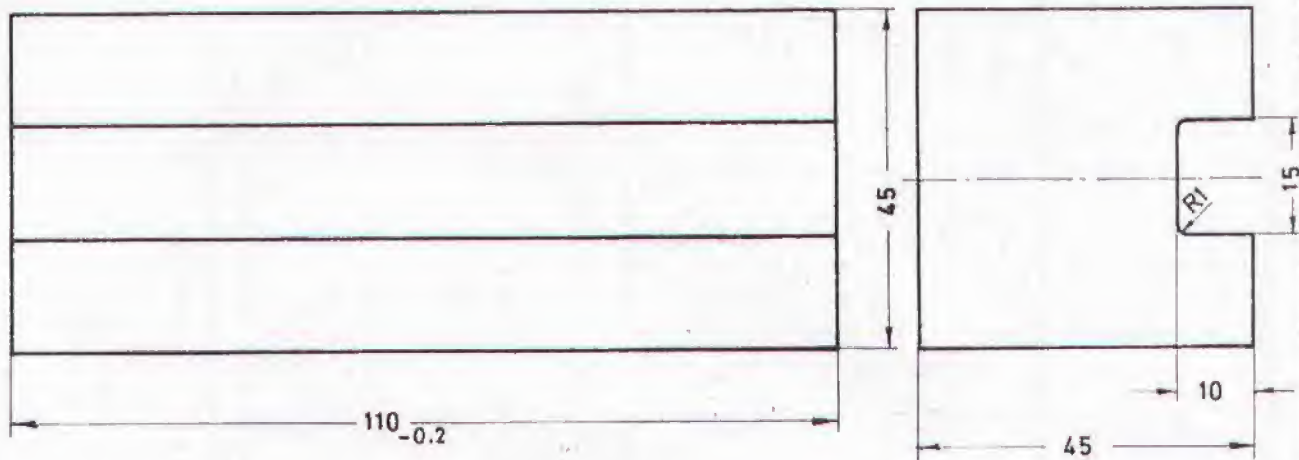

مزید کتب پڑھنے کے لئے آج ہی وزٹ کریں : www.iqbalkalmati.blogspot.com

SEQUENCE OF OPERATIONS

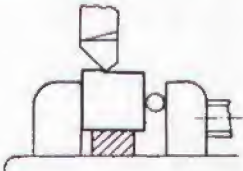
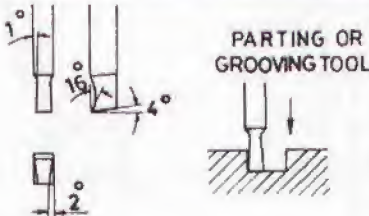
No	Symbol	Tools	Description
1		STRAIGHT LEFT-HAND ROUGHING AND FINISHING TOOL	SHAPING TO THE DIMENSION 45 x 45 AND LENGTH 110
2		GROOVING TOOL GRINDING GAUGE	GRINDING OF THE GROOVING TOOL TO THE CORRECT ANGLES AND 1 MM RADIUS ON BOTH CUTTING POINTS. SHAPING OF THE GROOVE.

SCALE 1:1

MAT: MILD STEEL

TOOL HOLDER

(For tool post)

No. 3.2.1/1

SHAPING III



DEVELOPMENT CELL FOR SKILLED LABOUR TRAINING

PAK-GERMAN TECHNICAL TRAINING PROGRAMME

MACHINIST

1 

Tolerance ± 0.1
unless otherwise stated.

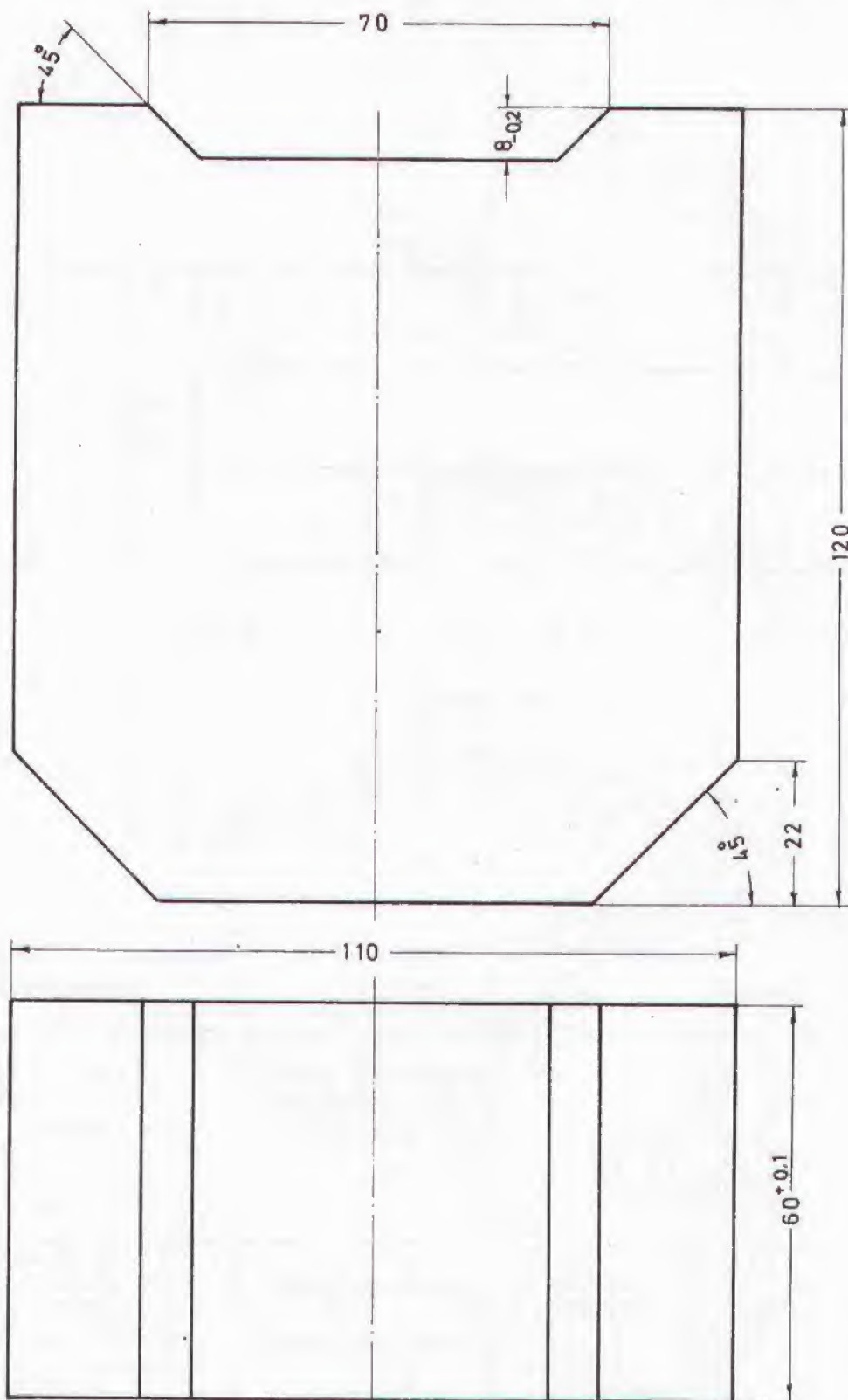

مزید کتب پڑھنے کے لئے آج ہی وزٹ کریں : www.iqbalkalmati.blogspot.com

SCALE 1 : 1

MAT: CAST IRON

BASE PLATE

(For tool post)

No. 3.2.1/2

SHAPING III



DEVELOPMENT CELL FOR SKILLED LABOUR TRAINING

PAK-GERMAN TECHNICAL TRAINING PROGRAMME

MACHINIST



Tolerance $\pm 0,2$ mm
unless otherwise stated

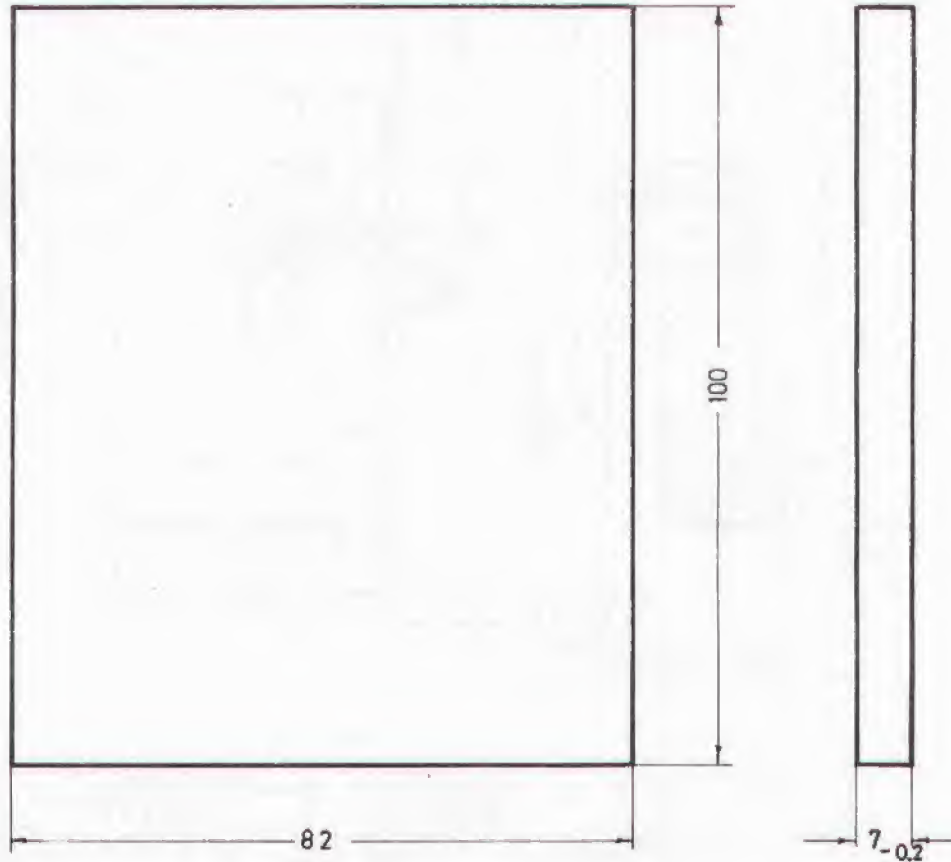

مزید کتب پڑھنے کے لئے آج ہی وزٹ کریں : www.iqbalkalmati.blogspot.com

SCALE 1:1	PLATE (for disk cam)	No. 3.2.1 / 3
MAT. MILD-STEEL		SHAPING III
	DEVELOPMENT CELL FOR SKILLED LABOUR TRAINING PAK-GERMAN TECHNICAL TRAINING PROGRAMME	MACHINIST



Tolerance ± 0.1
unless otherwise stated

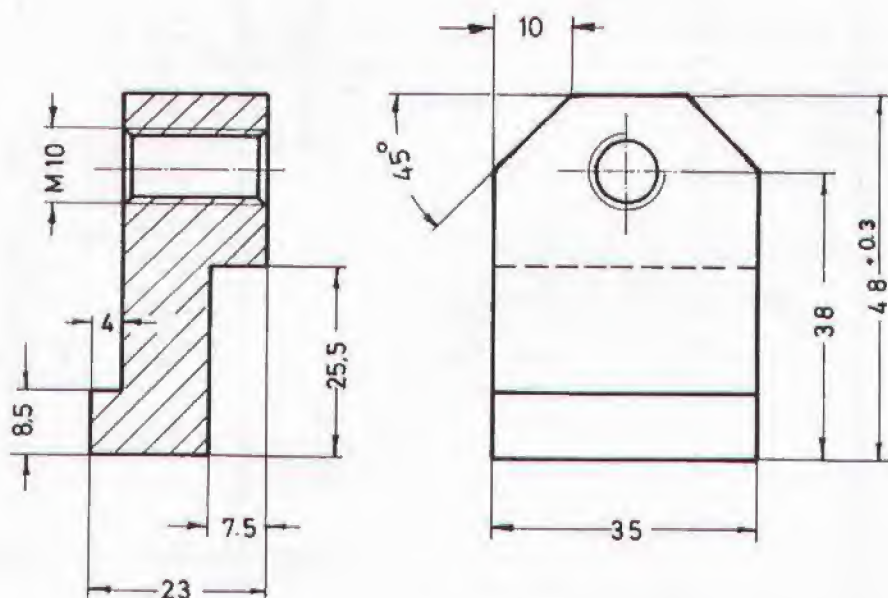

مزید کتب پڑھنے کے لئے آج ہی وزٹ کریں : www.iqbalkalmati.blogspot.com

SCALE 1:1

MAT. MILD-STEEL

CLAMPING PIECE

No. 3.2.1/4

SHAPING IIII



DEVELOPMENT CELL FOR SKILLED LABOUR TRAINING

PAK-GERMAN TECHNICAL TRAINING PROGRAMME

MACHINIST



Tolerance ± 0.1
unless otherwise stated.

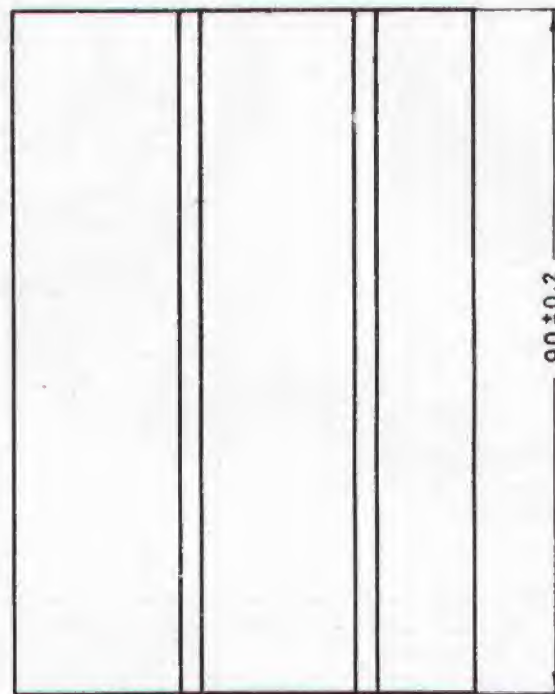
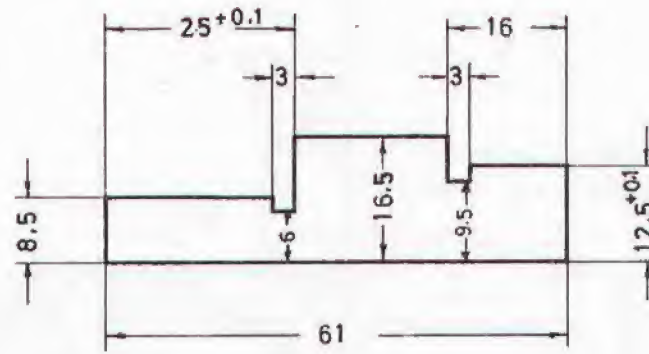

مزید کتب پڑھنے کے لئے آج ہی وزٹ کریں: www.iqbalkalmati.blogspot.com

SCALE 1:1	SLIDE RAIL	No. 3.2.1/5
MAT. MILD STEEL		SHAPING III
	DEVELOPMENT CELL FOR SKILLED LABOUR TRAINING PAK-GERMAN TECHNICAL TRAINING PROGRAMME	MACHINIST



Tolerance ± 0.1
unless otherwise stated.

مزید کتب پڑھنے کے لئے آج ہی وزٹ کریں : www.iqbalkalmati.blogspot.com

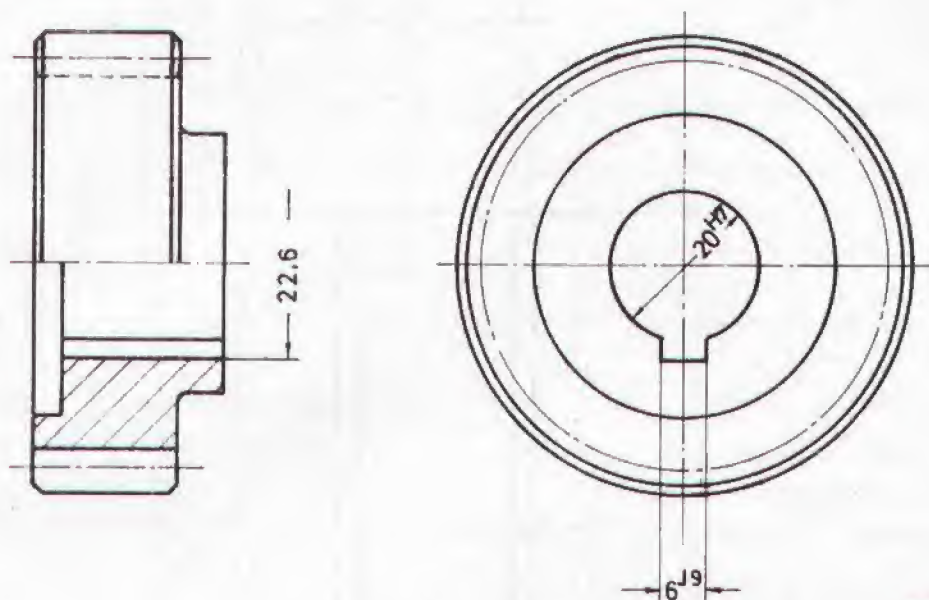

H7	+0,021
20	0
6J9	+0,021 -0,022

SEQUENCE OF OPERATIONS

No	Symbol	Tools	Description
1		KEYWAY TOOL-HOLDER PARALLEL BARS GAUGE BLOCKS	MARK OUT THE KEYWAY CLAMP THE GEAR AS SHOWN IN THE SKETCH
2		CUTTING TOOL TRY SQUARE VERNIER CALIPER	MAKE SURE THAT THE RADIAL LINE IS PERPENDICULAR AND IN CENTRE OF TOOL BIT

SCALE 1:1	GEAR From Machinist / Milling II	No. 3.2.1/6
MAT. MILD STEEL		SHAPING III

	DEVELOPMENT CELL FOR SKILLED LABOUR TRAINING	MACHINIST
	PAK-GERMAN TECHNICAL TRAINING PROGRAMME	

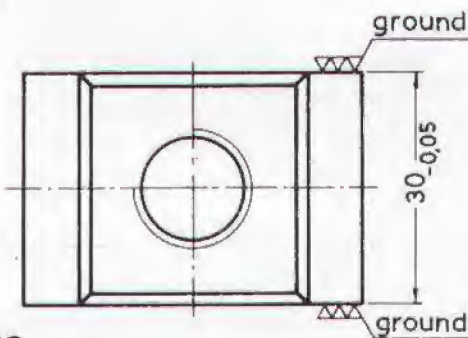
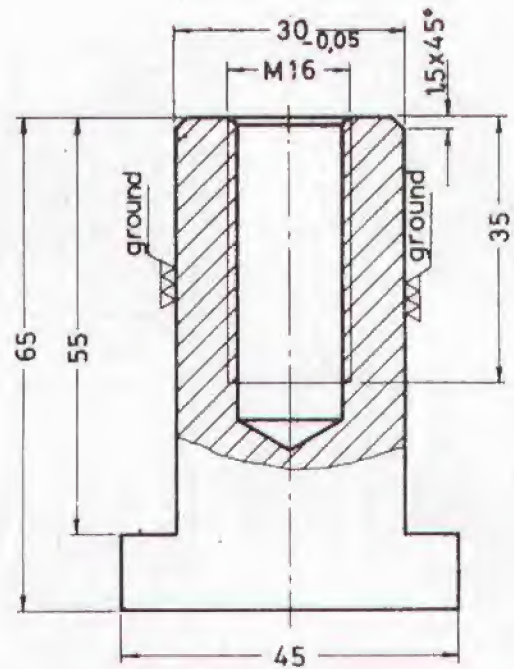

3 

Tolerance ± 0.1
Unless otherwise stated

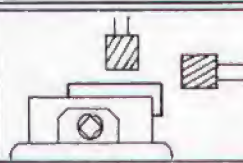

The thread hole will be made in Fitter section during assembling.

SEQUENCE OF OPERATIONS

No.	Symbol	Tools	Descriptions
1		SHELL END MILL PARALLEL BARS MEASURING INSTRUMENTS	MILL TO THE OUTSIDE DIMENSIONS 65 x 45 x 30.4
2			RECLAMP AND MILL THE STEP MIND THE GRINDING ALLOWANCE

SCALE 1:1
MAT. MILD STEEL

CLAMPING PIECE
(For tool post)

No. 3.2.2 / 1
MILLING II

5 

Tolerance $\pm 0,1$ mm
unless otherwise stated.

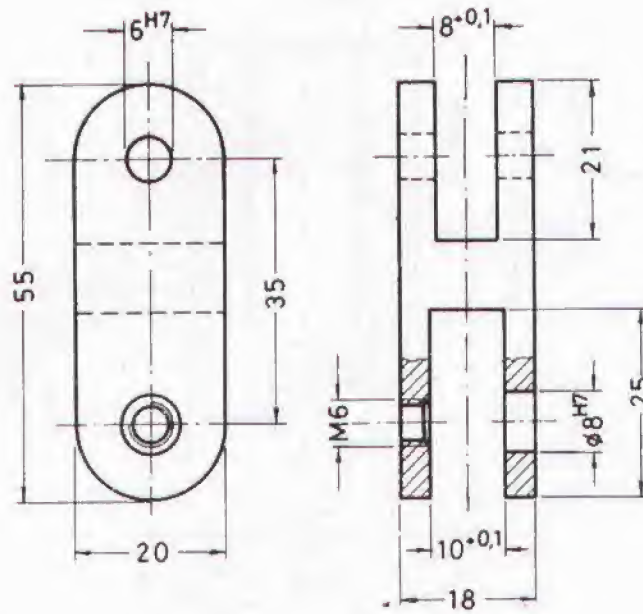

The holes and radii have to be made in Fitter-section during assembling.

6^{H7}	$+0,012$ 0
8^{H7}	$+0,015$ 0

SEQUENCE OF OPERATIONS

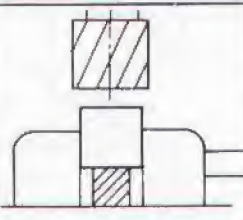
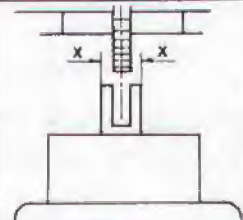
No.	Symbol	Tools	Descriptions
1		SHELL END MILL PARALLEL BARS MEASURING INSTRUMENTS	MILL TO THE DIMENSION 55 x 20 x 18 DEBURR MARK OUT THE SLOTS
2		SIDE MILLING CUTTER	MILL THE TWO SLOTS BY USING A SIDE MILLING CUTTER

SCALE 1:1	LINK (For lever press)	No. 3.2.2 / 2
MAT. MILD STEEL		MILLING II

	DEVELOPMENT CELL FOR SKILLED LABOUR TRAINING	MACHINIST
	PAK-GERMAN TECHNICAL TRAINING PROGRAMME	

5 ∇

Tolerance $\pm 0,1$
unless otherwise stated

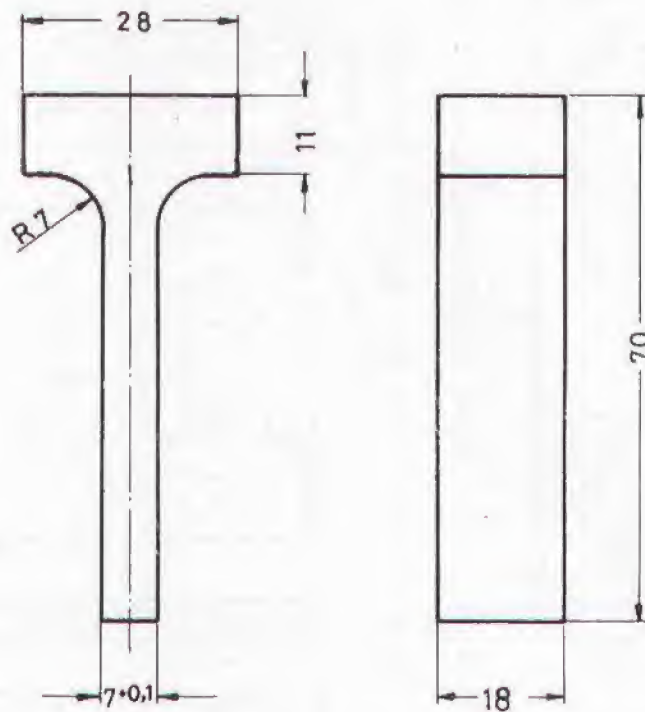

SEQUENCE OF OPERATIONS

No.	Symbol	Tools	Descriptions
1		SHELL END MILL PARALLEL BARS MEASURING INSTRUMENTS	MILL THE WORKPIECE TO THE DIMENSION 70 x 28 x 18
2		SHANK END MILL ϕ 14 MM	RECLAMP THE WORKPIECE MOUNT A 14 MM SHANK END MILL AND CUT TO THE REQUIRED SIZE

SCALE 1:1

MAT. L.C.STEEL

JAW

(For hand vice)

No. 3.2.2 / 3



MILLING II



DEVELOPMENT CELL FOR SKILLED LABOUR TRAINING

PAK-GERMAN TECHNICAL TRAINING PROGRAMME

MACHINIST

2  ()

Tolerance $\pm 0,1$
unless otherwise stated

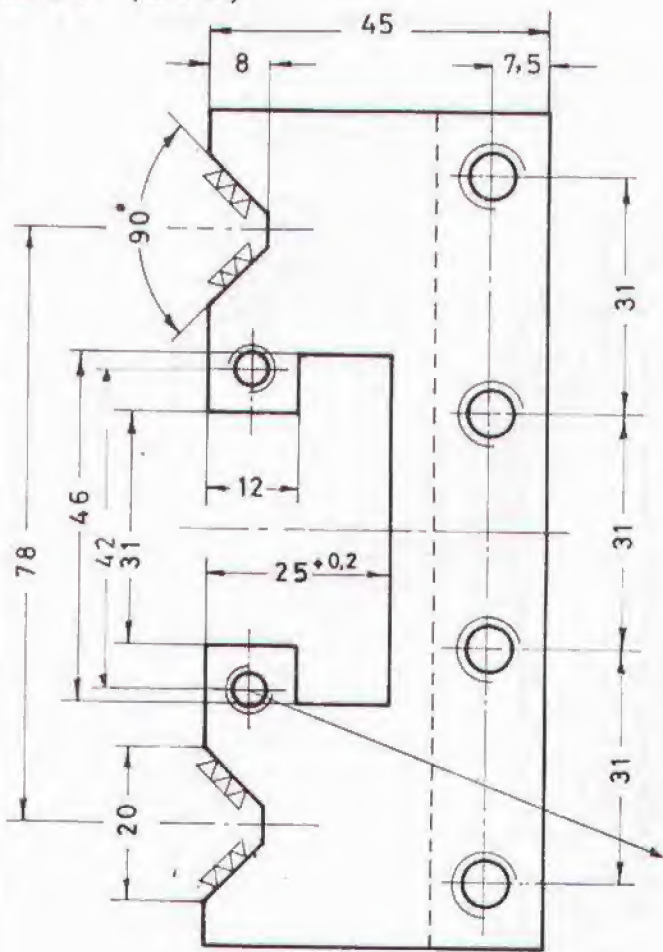

Drilled together with part No.8

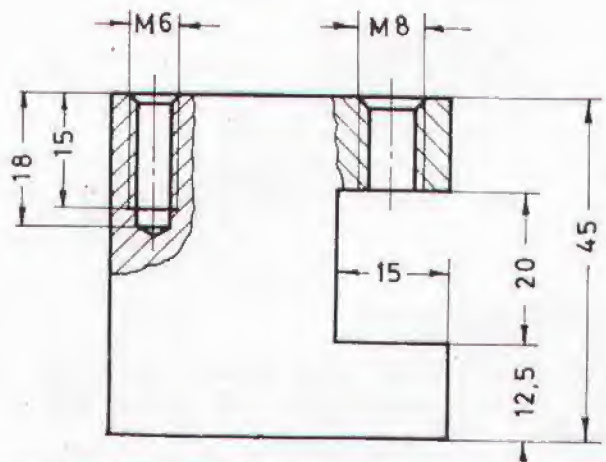
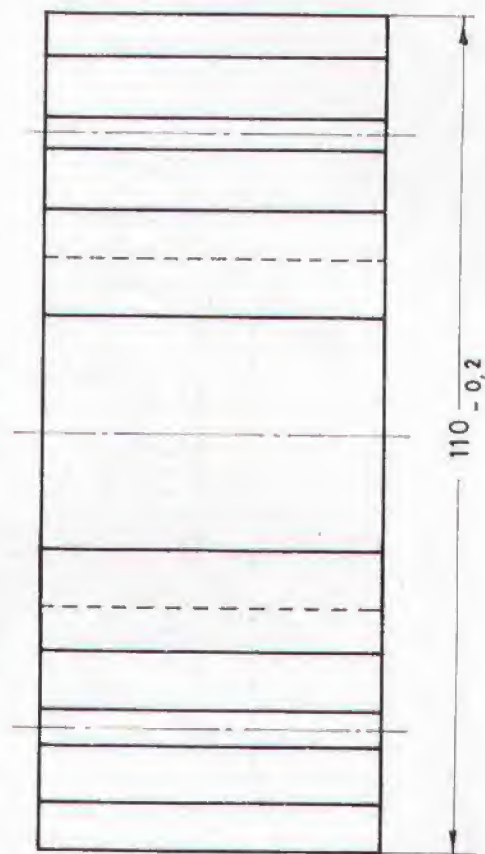

Holes and threads have to be done by Tool & Die Maker during assembling.

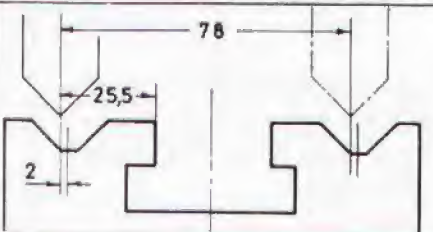
Symbol	Description
	MARKING OF THE T- AND V-SLOTS. MILLING OF T-SLOT, BY USING A STRAIGHT SIDE AND T-SLOT MILLING CUTTER. MOUNTING A 90° DOUBLE ANGLE CUTTER. MILLING OF THE V-SLOTS AS SHOWN IN THE SKETCH. MILLING OF THE SLOT 15 x 20 MM.

SCALE 1:1

MAT. MILD STEEL

TOOL HOLDER

From Machinist/Shaping III

(For tool post)

No. 3.2.2 / 4

MILLING II



DEVELOPMENT CELL FOR SKILLED LABOUR TRAINING

PAK-GERMAN TECHNICAL TRAINING PROGRAMME

MACHINIST

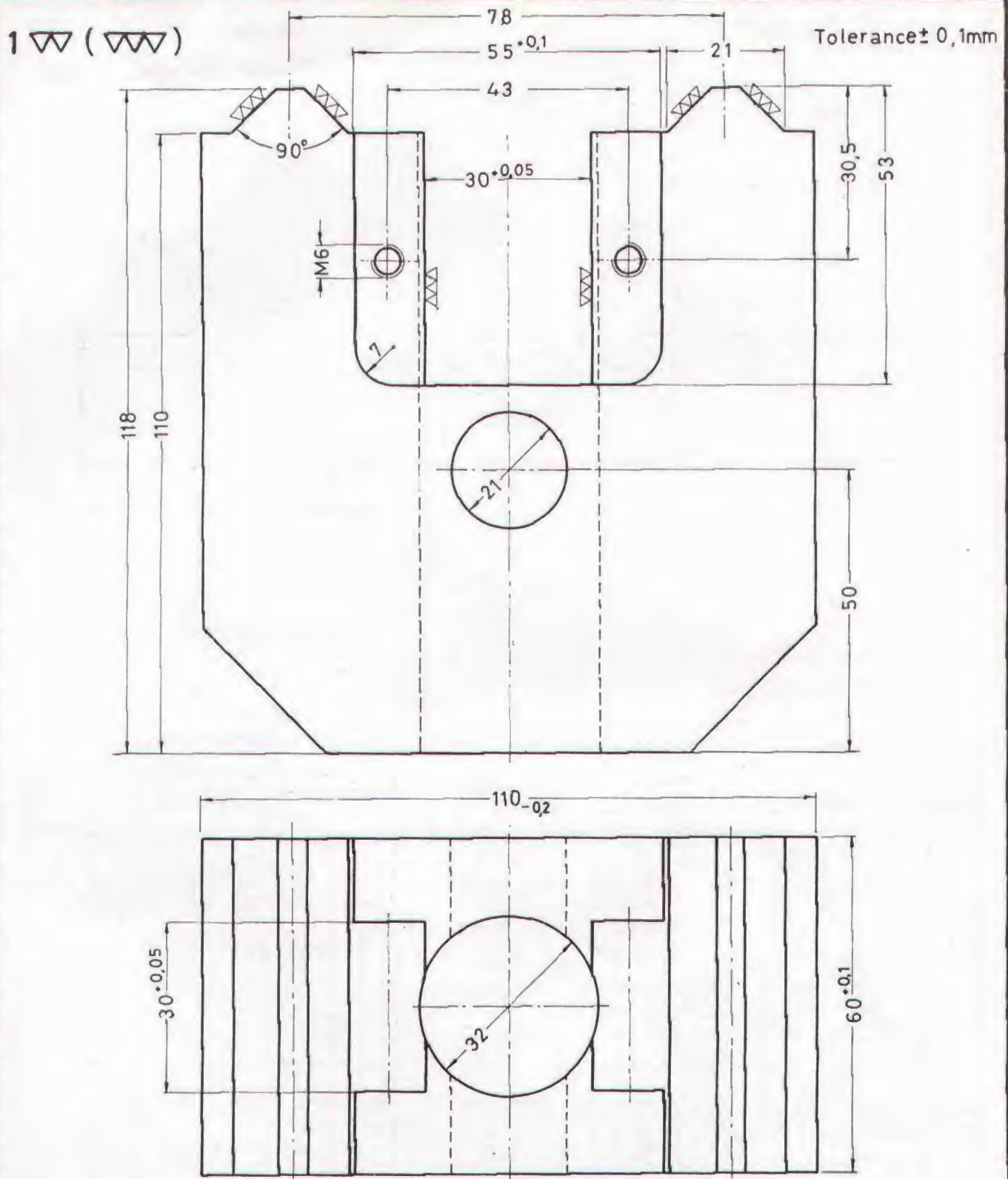

Holes and threads have to be done by Tool & Die Maker during assembling.

SCALE 1:1

MAT. CAST IRON

BASE PLATE

From Machinist / Shaping III

(For tool post)

No. 3.2.2 / 5

MILLING II



DEVELOPMENT CELL FOR SKILLED LABOUR TRAINING

PAK-GERMAN TECHNICAL TRAINING PROGRAMME

MACHINIST



Tolerance ± 0.1
unless otherwise stated

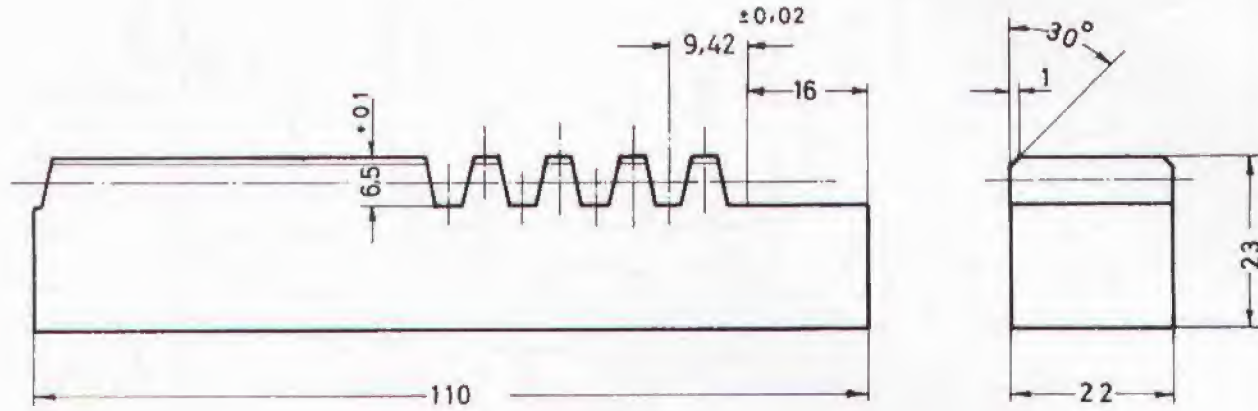

مزید کتب پڑھنے کے لئے آج ہی وزٹ کریں : www.iqbalkalmati.blogspot.com

Module 3

SEQUENCE OF OPERATIONS

No.	Symbol	Tools	Descriptions
1		SHELL END MILL PARALLEL BAR MEASURING EQUIP- MENT	MILL THE WORKPIECE TO THE REQUIRED OUTSIDE DIMEN- SIONS CHAMFER AND DEBURR
2		MODULE CUTTER M = 3 NO. 8 DIAL INDICATOR WITH MAGNETIC STAND	MOUNTING OF MODULE CUTTER CUTTING OF TOOTH PROFILE AFTER EACH CUT ADJUST THE DIAL INDICATOR TO ZERO BEFORE MOVING THE TABLE

SCALE 1:1

MAT. MILD-STEEL

RACK

No. 3.2.2 / 6

MILLING II



DEVELOPMENT CELL FOR SKILLED LABOUR TRAINING

PAK-GERMAN TECHNICAL TRAINING PROGRAMME

MACHINIST

مزید کتب پڑھنے کے لئے آج ہی وزٹ کریں : www.iqbalkalmati.blogspot.com

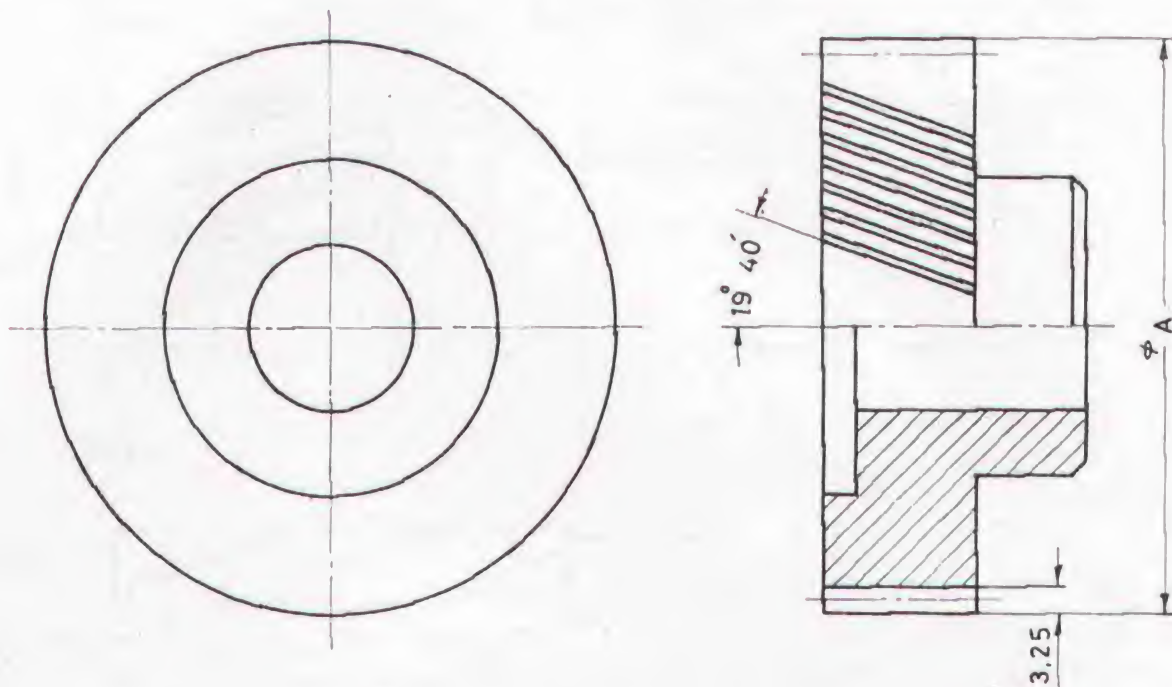

$A = \phi 66.7$	No. of teeth = 40	Mod. 1,5	Lead 560 mm
$A = \phi 95.2$	No. of teeth = 58	Mod. 1,5	Lead 810 mm

SEQUENCE OF OPERATIONS

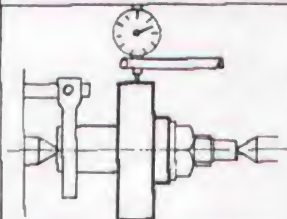
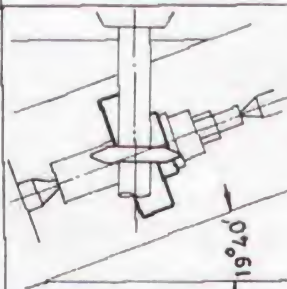
No.	Symbol	Tools	Descriptions
1		GEAR CUTTING ATTACHMENT TAIL STOCK DIAL INDICATOR	MOUNTING AND ALIGNING OF INDEXING HEAD AND TAILSTOCK HOLD WORKPIECE BETWEEN CENTRES CHECK TRUE RUNNING
2		MODULE CUTTER $M = 1.5$ NO. 6 $M = 1.5$ NO. 7	ADJUSTING THE TABLE TO $19^{\circ}40'$ SETTING THE WORKPIECE TO THE CENTRE OF THE CUTTER SETTING TO THE REQUIRED LEAD

SCALE 1:1

MAT. MILD STEEL
CAST IRON

HELICAL GEAR WHEELS

From Turner/Turning II + Tool & Die Maker / Turning II

No. 3.2.217

MILLING II



DEVELOPMENT CELL FOR SKILLED LABOUR TRAINING

PAK-GERMAN TECHNICAL TRAINING PROGRAMME

MACHINIST



Tolerance $\pm 0,1$
unless otherwise stated

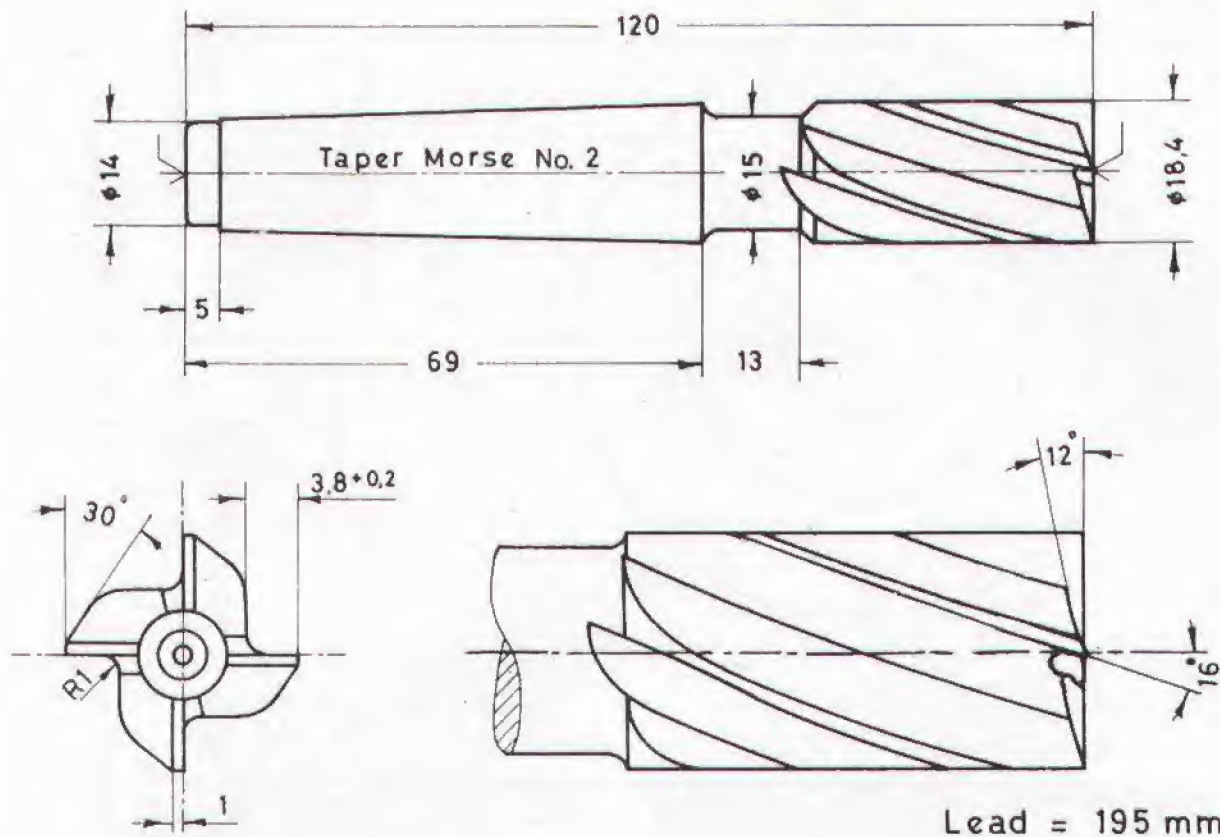

SEQUENCE OF OPERATIONS

No	Symbol	Tools	Descriptions
1		INDEXING HEAD TAILSTOCK SHANK END MILL ϕ 12 - 14 MM	MOUNTING OF THE INDEXING HEAD AND TAILSTOCK AS WELL AS GEARS FOR HELICAL MILLING LEAD 195 MM
2			TO GET A PROPER CLEARANCE CUT, SWIVEL THE VERTICAL HEAD TO AN ANGLE OF 18° AS SHOWN IN THE SKETCH. MILLING OF THE FLUTE AND CLEARANCE ANGLE 30°

SCALE 1:1
2:1

MAT. HIGH SPEED
STEEL

TAPER SHANK END MILL

From: M/W.Turn II - Tool & Die Maker / Turning II

No. 3.2.2 / 8

MILLING II



DEVELOPMENT CELL FOR SKILLED LABOUR TRAINING

PAK-GERMAN TECHNICAL TRAINING PROGRAMME

MACHINIST



Tolerance ± 0.1
Unless otherwise stated

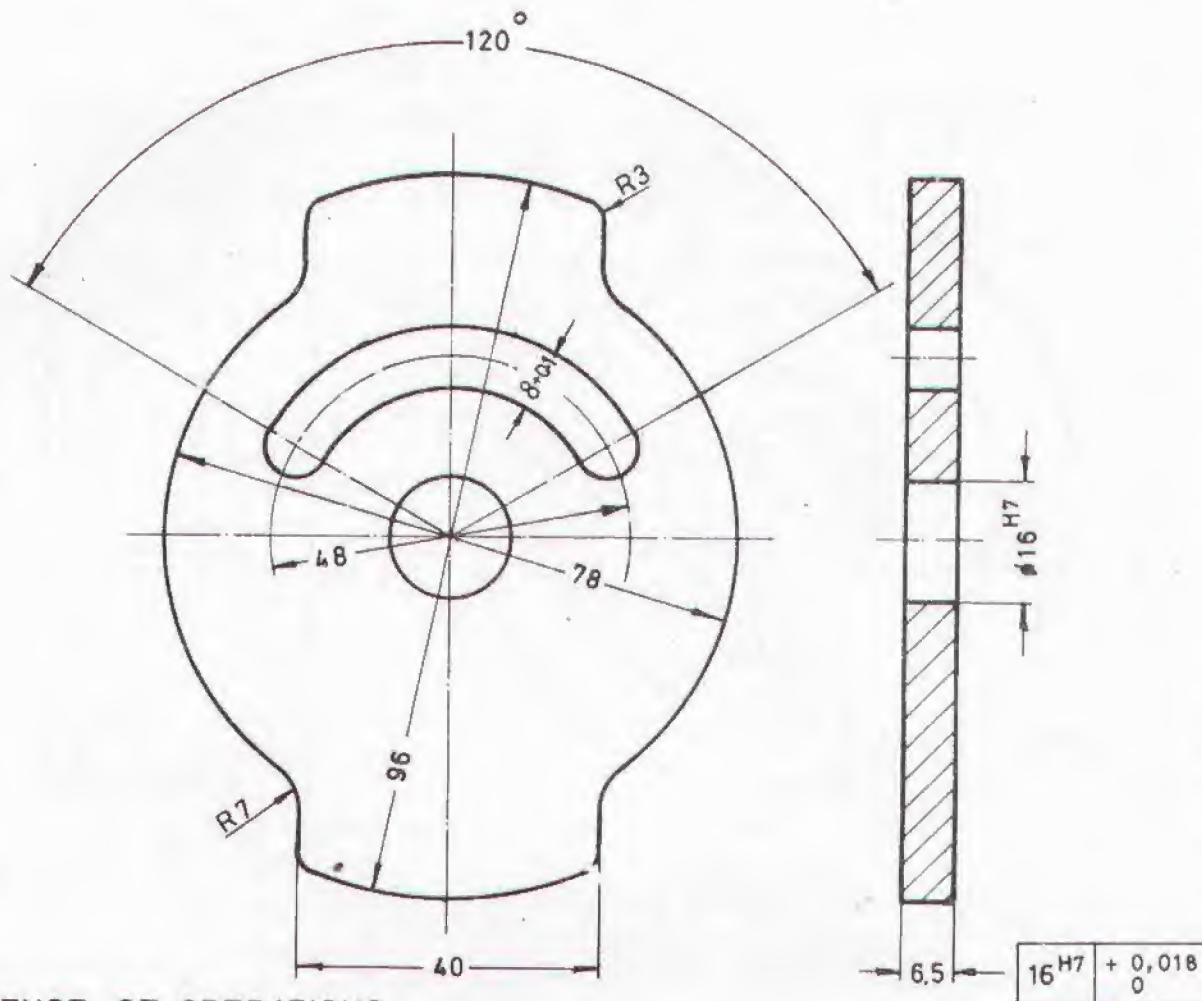

SEQUENCE OF OPERATIONS

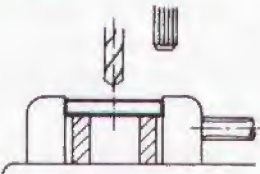
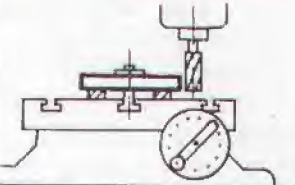
No.	Symbol	Tools	Descriptions
1		TWIST DRILL REAMER PARALLEL BARS MARKING EQUIPMENT	MARK OUT THE CENTRE HOLE AND RADII DRILL AND REAM THE CENTRE HOLE
2		ROTARY TABLE SHANK END MILL ϕ 14 MM TWO FLUTE END MILL ϕ 8 MM	MOUNT THE ROTARY TABLE & CLAMP THE WORKPIECE CONCENTRICALLY. USE A CENTRE BOLT. MACHINE THE DISK CAM ACCORDINGLY.

SCALE 1:1

DISK CAM

No. 3.2.2 / 9

MAT. MILD STEEL

From Machinist / Surface grinding

MILLING II



DEVELOPMENT CELL FOR SKILLED LABOUR TRAINING

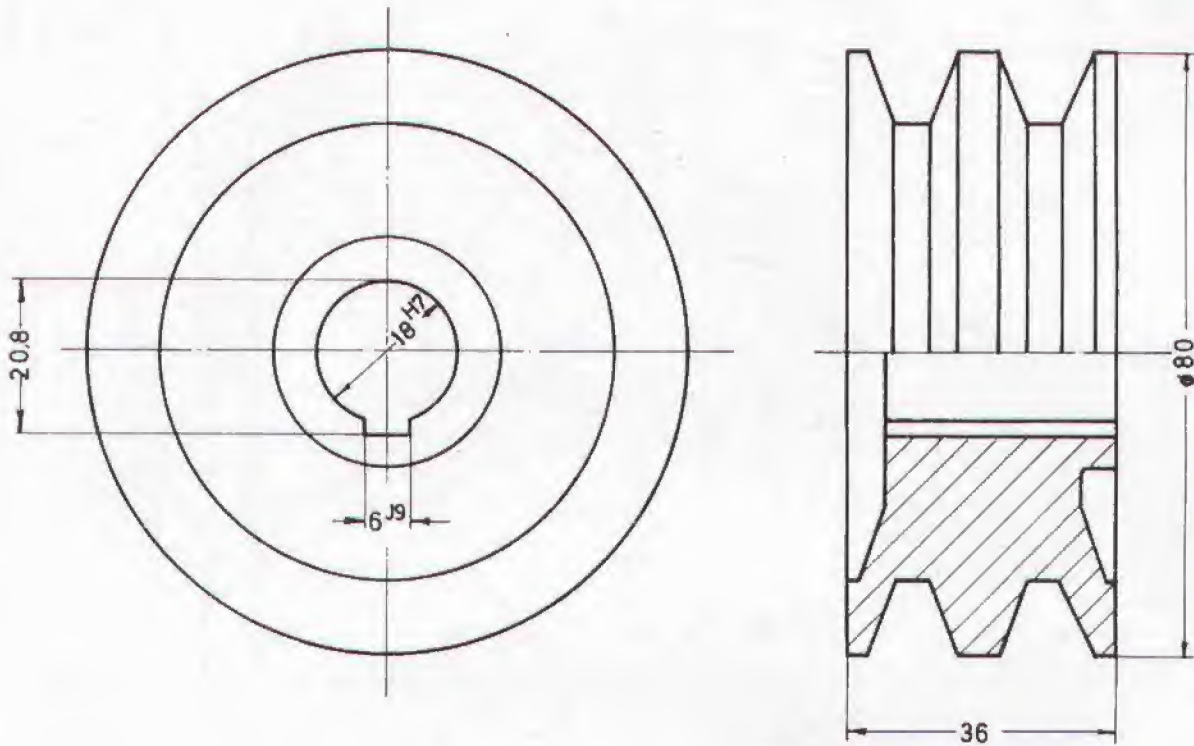

PAK-GERMAN TECHNICAL TRAINING PROGRAMME

MACHINIST

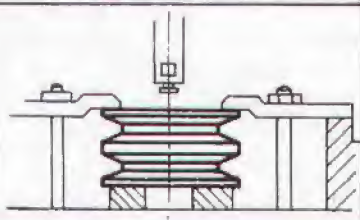

SEQUENCE OF OPERATIONS

6^{J9}	+0,021 -0,022
----------	------------------

No.	Symbol	Tools	Descriptions
1		SLOTTING ATTACHMENT CLAMPS MARKING EQUIPMENT	MARK OUT THE KEYWAY CLAMP THE PULLEY DIRECTLY ON THE TABLE AS SHOWN IN THE SKETCH
2			ADJUST THE WORKTABLE UNTIL THE RADIAL LINE IS CENTRAL WITH THE TOOL BIT. TAKE ONE STROKE BY HAND TO BE SURE THAT THERE IS NO INTERFERENCE.

SCALE 1:1

PULLEY

No. 3.2.2/10

MAT.MILD STEEL

From Turner / Turning II

MILLING II



DEVELOPMENT CELL FOR SKILLED LABOUR TRAINING

PAK-GERMAN TECHNICAL TRAINING PROGRAMME

MACHINIST

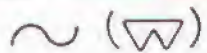

Tolerance ± 0.1

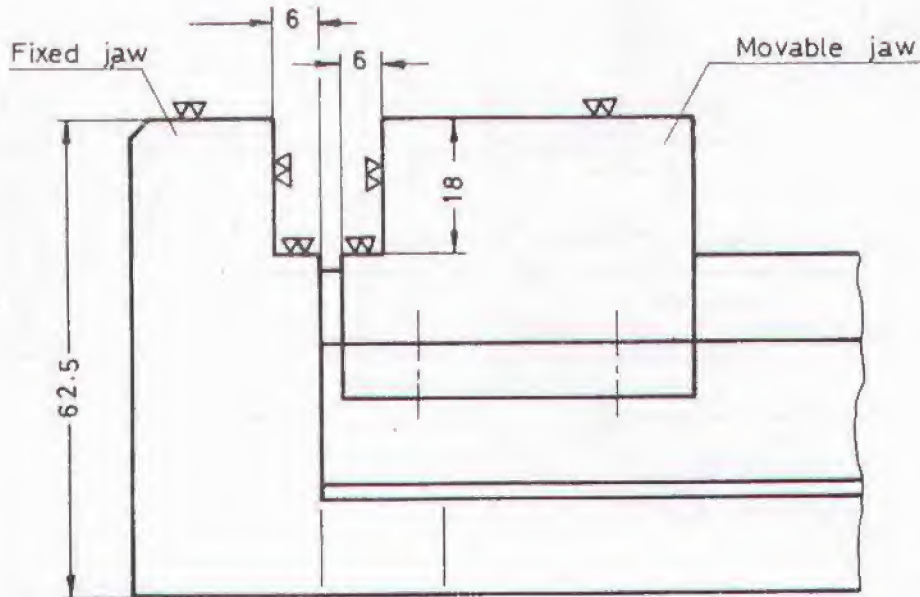

SEQUENCE OF OPERATIONS

No	Symbol	Tools	Descriptions
1			FIXING OF THE MOVABLE JAW BY THE HELP OF A SHIM WHICH HAS TO BE CLAMPED BETWEEN THE SLIDE AND THE SLIDE PLATE
2		SHELL END MILL CUTTER	PLAN MILLING OF THE TOP TO THE DIMENSION OF 62,5 MM
3		SIDE MILLING CUTTER	FINISHING OF THE STEPS FOR THE JAWS

SCALE 1:1	MACHINE VICE <small>From: Millwright / Fitting III</small>	No. 3.2.2/12
MAT.: CAST IRON		MILLING II

	DEVELOPMENT CELL FOR SKILLED LABOUR TRAINING	MACHINIST
	PAK-GERMAN TECHNICAL TRAINING PROGRAMME	

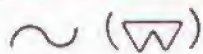

Tolerance ± 0.1

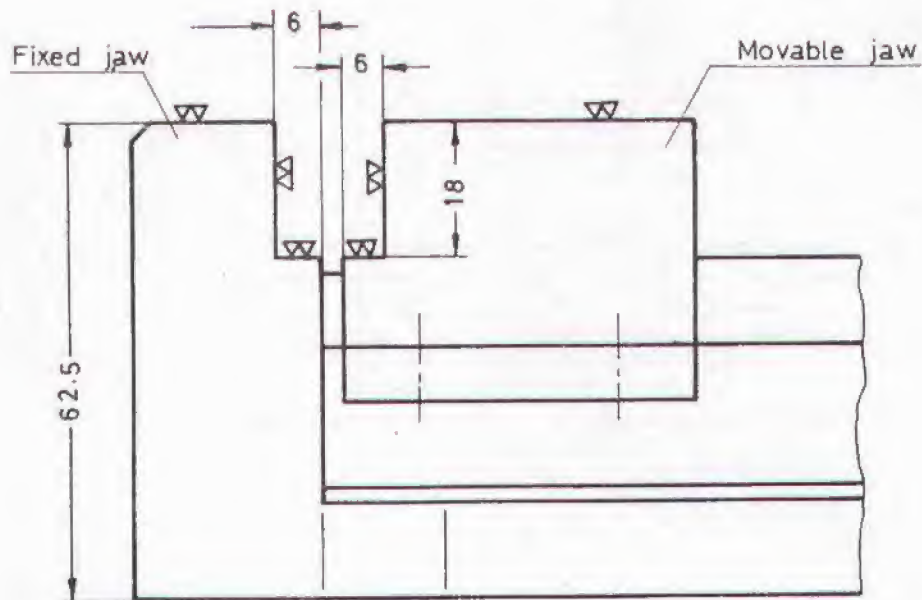

SEQUENCE OF OPERATIONS

No	Symbol	Tools	Descriptions
1			FIXING OF THE MOVABLE JAW BY THE HELP OF A SHIM WHICH HAS TO BE CLAMPED BETWEEN THE SLIDE AND THE SLIDE PLATE
2		SHELL END MILL CUTTER	PLAN MILLING OF THE TOP TO THE DIMENSION OF 62,5 MM
3		SIDE MILLING CUTTER	FINISHING OF THE STEPS FOR THE JAWS

SCALE 1:1

MAT.: CAST IRON

From: Millwright / Fitting III

MACHINE VICE

No. 3.2.2/12

MILLING II



DEVELOPMENT CELL FOR SKILLED LABOUR TRAINING

PAK-GERMAN TECHNICAL TRAINING PROGRAMME

MACHINIST

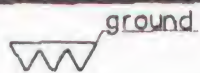

Tolerance $\pm 0,1$
unless otherwise stated.

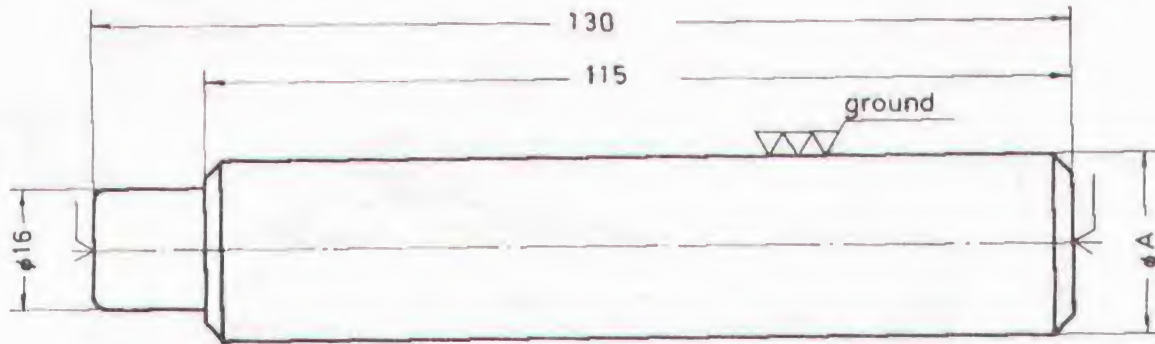

	ϕA	MARKS GIVEN BY THE INST
1.	$\phi 23,7 \pm 0,05$	
2.	$\phi 23,4 \pm 0,03$	
3.	$\phi 23,2 \pm 0,03$	
4.	$\phi 23,0 \pm 0,02$	
5.	$\phi 22,8 \pm 0,02$	
6.	$\phi 22,7 \pm 0,01$	

SEQUENCE OF OPERATIONS

No	Symbol	Tools	Description
	<p>Wheel-dresser.</p>	GRINDING WHEEL WHEEL DRESSER	SELECTING OF A GRINDING WHEEL SUITABLE FOR UN-HARDENED STEEL MOUNTING AND DRESSING OF THE GRINDING WHEEL
2		MICROMETER 0 - 25 MM	HOLDING THE WORKPIECE BETWEEN CENTRES. ADJUSTING THE STOPS AND SPEED FOR THE WORKPIECE GRINDING TO THE REQUIRED DIAMETER.

SCALE 1:1

MAT: MILD STEEL

GRINDING EXERCISE

No. 3.2.3/ 1

CIRCULAR GRIND



DEVELOPMENT CELL FOR SKILLED LABOUR TRAINING

PAK-GERMAN TECHNICAL TRAINING PROGRAMME

MACHINIST

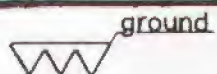

Tolerance ± 0.1
unless otherwise stated.

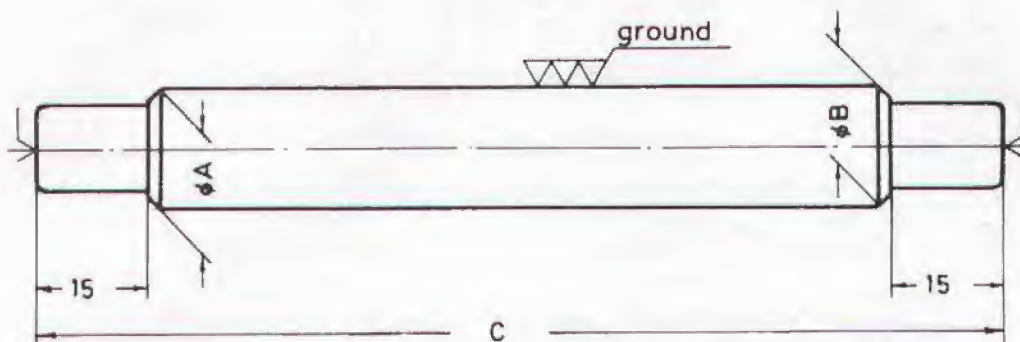

NOMINAL ϕ	ϕA	ϕB	C
10	$10.03^{+0.01}$	$9.98_{-0.01}$	95
12	$12.04^{+0.01}$	$11.98_{-0.01}$	115
14	$14.04^{+0.01}$	$13.98_{-0.01}$	115
16	$16.04^{+0.01}$	$15.98_{-0.01}$	130
18	$18.05^{+0.01}$	$17.98_{-0.01}$	130
20	$20.05^{+0.01}$	$19.98_{-0.01}$	160
22	$22.05^{+0.01}$	$21.98_{-0.01}$	160

SEQUENCE OF OPERATIONS

No	Symbol	Descriptions
1		CLEANING AND GREASING THE CENTRE-HOLES.
2		HOLDING BETWEEN CENTRES AND ADJUSTING THE STOPS, ROUGH GRINDING TO AN OVERSIZE 15/100 MM. SWIVEL THE TABLE SLIGHTLY BEFORE FINISHING TO GET THE REQUIRED TAPER.

SCALE 1:1

MAT: LOW CARBON-STEEL.

MANDRELS

From Turner / Turning II

No. 3.2.3/2

CIRC. GRINDING



DEVELOPMENT CELL FOR SKILLED LABOUR TRAINING

PAK-GERMAN TECHNICAL TRAINING PROGRAMME

MACHINIST

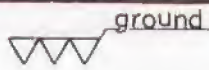

Tolerance ± 0.1
unless otherwise stated.

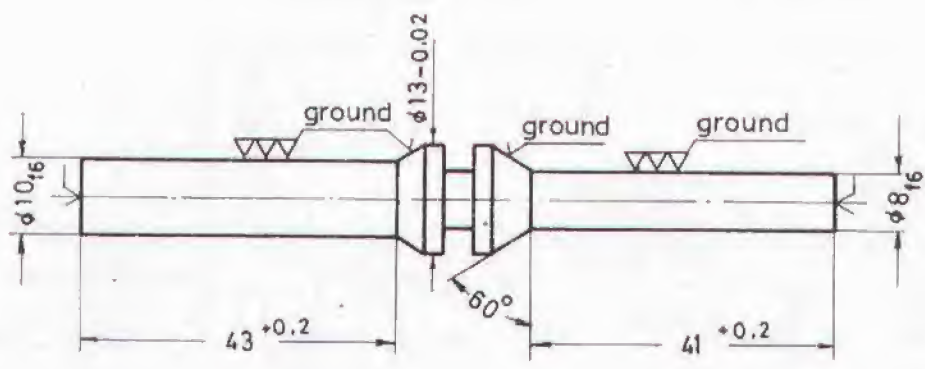

8_{f6}	-0,013
10_{f6}	-0,022

SEQUENCE OF OPERATIONS

No	Symbol	Tools	Description
1		GRINDING WHEEL . WITH 30° CHAMFER MICROMETER 0-25 MM	MOUNTING OF THE GRINDING WHEEL PROVIDED WITH A CHAMFER OF 30°. ROUGH GRINDING OF ALL DIAMETERS AND CHAMFERS.
2		DIAMOND-WHEEL DRESSER	DRESSING THE GRINDING WHEEL. SWIVEL THE HEADSTOCK TO 30° FOR DRESSING THE CHAMFER. FINISH GRINDING.

SCALE 1:1
MAT: CARBON ST.

PUNCH
From Turner / Turning II

No. 3.2.3/3
CIRC. GRINDING



DEVELOPMENT CELL FOR SKILLED LABOUR TRAINING

PAK-GERMAN TECHNICAL TRAINING PROGRAMME

MACHINIST



Tolerance ± 0.1
unless otherwise stated.

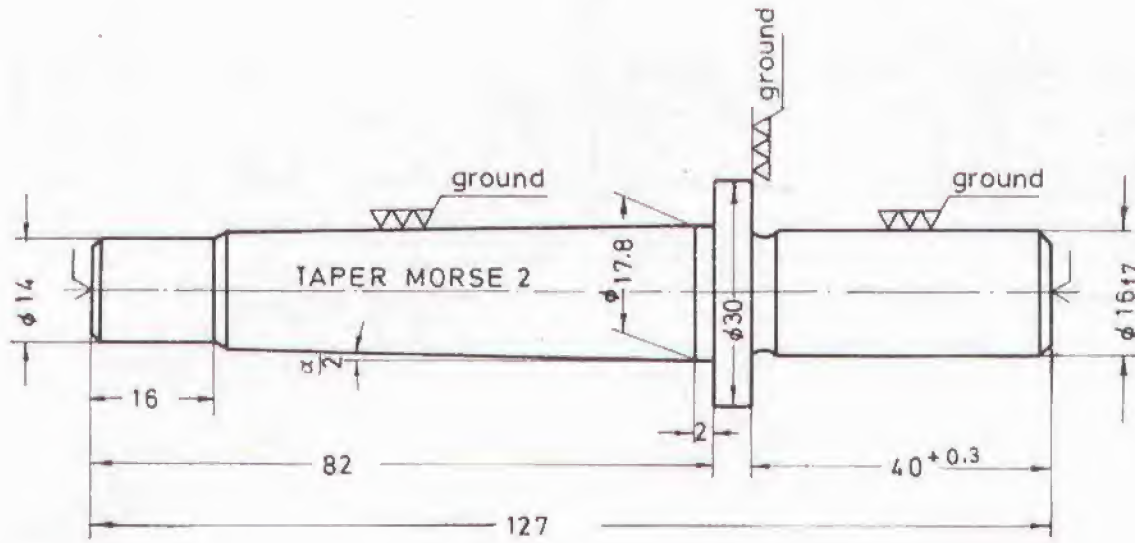

$$\frac{\alpha}{2} = 1^{\circ} 25'$$

16 _{f7}	-0.016
	-0.034

SEQUENCE OF OPERATIONS

No	Symbol	Tools	Descriptions
1		ONE SIDE RELIEVED GRINDING WHEEL MICROMETER	DRESSING OF A SLIGHTLY CONCAVED CLEARANCE ON THE LEFT SIDE OF THE WHEEL TO ENSURE THE PRODUCTION OF A FLAT SHOULDER
2			SWIVELING THE TABLE FOR THE REQUIRED TAPER. GRINDING UNTIL THE TAPERED SECTION JUST CLEANS UP
3		TAPER RING GAUGE MORSE NO. 2	CHECK THE TAPER FOR ACCURACY AND READJUST THE TABLE IF NECESSARY. FINISH GRINDING ACCORDING TO TAPER GAUGE.

SCALE 1:1	ARBOR From Turner / Turning II	No. 3.2.3/4
MAT. LOW CARBON STEEL		CIRC. GRINDING

	DEVELOPMENT CELL FOR SKILLED LABOUR TRAINING	MACHINIST
	PAK-GERMAN TECHNICAL TRAINING PROGRAMME	

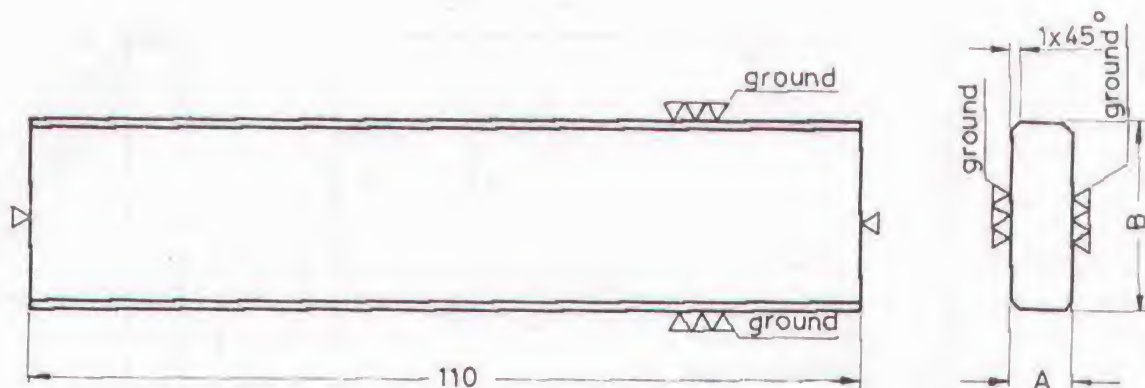

2 Pieces

	B	B	B	A	Marks given
1	19.5 ± 0.03	24.5 ± 0.03	29.5 ± 0.03	7.5 ± 0.03	
2	19.2 ± 0.02	24.2 ± 0.02	29.2 ± 0.02	7.2 ± 0.02	
3	19.0 ± 0.01	24.0 ± 0.01	29.0 ± 0.01	7.0 ± 0.01	

SEQUENCE OF OPERATIONS

No.	Symbol	Descriptions
1		REMOVING OF ALL BURRS FROM THE WORKPIECES. CLEANING OF THE MAGNETIC CHUCK. PLACING A PAIR OF WORKPIECES ON THE MAGNETIC CHUCK. GRINDING TO THICKNESS OF 7.5 MM WITH A TOLERANCE ± 0.03 MM. CHECKING BY YOUR INSTRUCTOR AFTER EACH WORKSTEP.
2		HOLDING THE WORKPIECE AS SHOWN. PLACING OF STEEL PARALLELS AGAINST THE EDGES OF THE WORK TO PREVENT IT FROM MOVING UNDER THE GRINDING FORCE. GRINDING TO WIDTH "B" AS REQUIRED IN THE WORKSTEPS. MIND THE TOLERANCES.

SCALE 1:1

MAT. CASE HARDENING STEEL

PARALLELS

From Turner / Shaping II

No. 3.2.4 / 1

SURFACE - GRINDING



DEVELOPMENT CELL FOR SKILLED LABOUR TRAINING

PAK-GERMAN TECHNICAL TRAINING PROGRAMME

MACHINIST

▽ (ground)

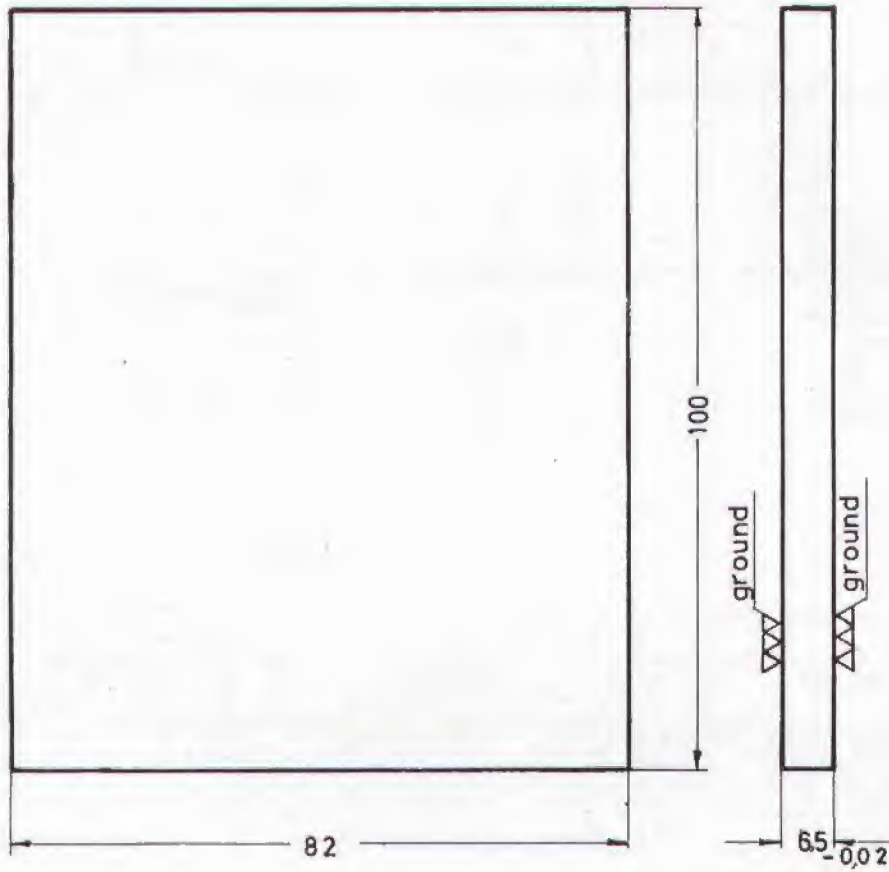

SCALE 1:1	PLATE From Machinist/Shaping III (For disk cam)	No. 3.2.4 / 2
MAT. MILD-STEEL		SURFACE-GRINDING
DEVELOPMENT CELL FOR SKILLED LABOUR TRAINING PAK-GERMAN TECHNICAL TRAINING PROGRAMME		MACHINIST

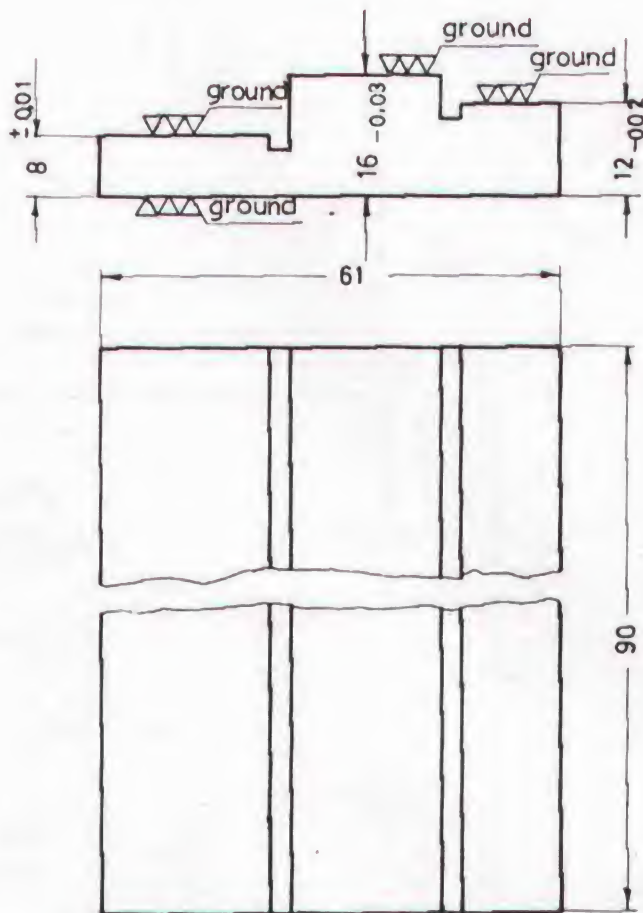
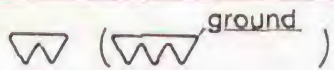

SEQUENCE OF OPERATIONS

No.	Symbol	Descriptions
1		CLAMPING OF THE WORKPIECE IN A GRINDING VICE - SUPPORTED BY MEANS OF PARALLEL BAR. MOUNTING OF THE VICE ON THE MAGNETIC CHUCK. GRINDING OF THE BASE SURFACE. DEBURRING OF WORKPIECE. CLEANING OF MAGNETIC CHUCK.
2		PLACING OF WORKPIECE ON MAGNETIC CHUCK. GRINDING TO THICKNESS 16 MM. PLACING OF THE WORKPIECE PARALLEL TO THE TABLE MOVEMENT. GRINDING OF THE STEPS 12 MM & 8 MM.

SCALE 1:1

SLIDE RAIL

No. 3.2.4 / 3

MAT. MILD STEEL

From Machinist / Shaping III

SURFACE - GRIN.



DEVELOPMENT CELL FOR SKILLED LABOUR TRAINING

PAK-GERMAN TECHNICAL TRAINING PROGRAMME

MACHINIST



Tolerance $\pm 0,1$
unless otherwise stated

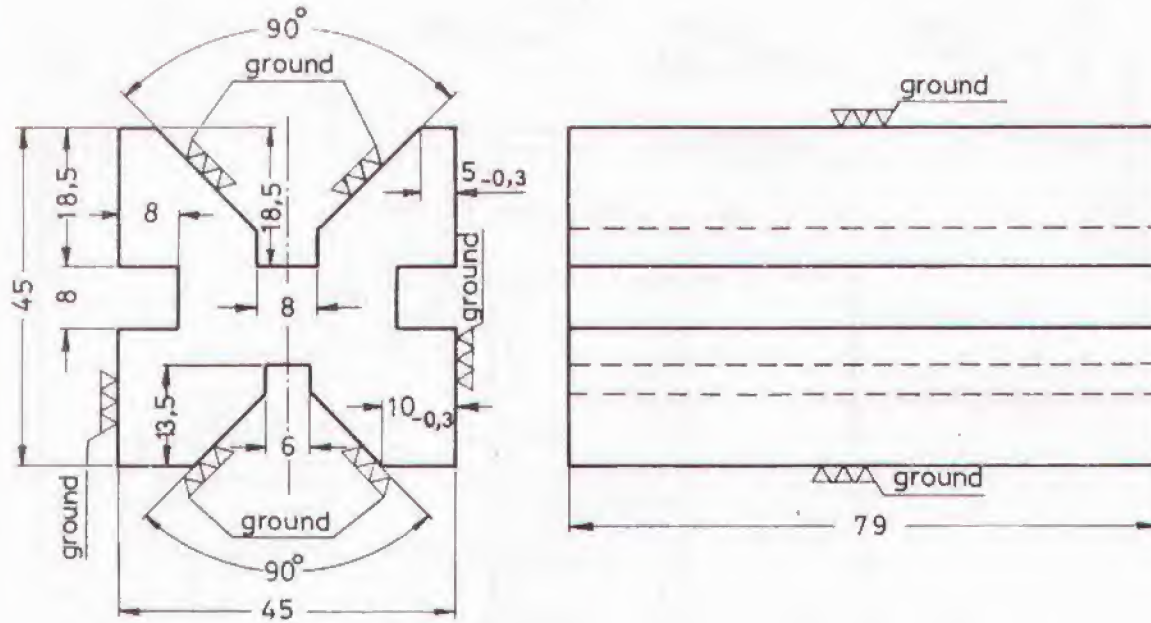

SEQUENCE OF OPERATIONS

No.	Symbols	Descriptions
1		GRINDING OF THE 4 OUTER SURFACES IN A PROPER SEQUENCE BY USING AN ANGLE PLATE TO ASSURE RIGHT ANGLES AND PARALLEL SURFACES. DEBURRING OF THE V-BLOCK. SWIVELING OF THE ANGLE PLATE TO 45°. CLAMPING OF THE WORKPIECE AS SHOWN. HOLDING THE ANGLE PLATE WITH HELP OF MAGNETIC CHUCK. MAKE SURE THAT THE ANGLE PLATE IS PARALLEL TO THE TABLE MOVEMENT.
2		GRINDING OF ONE SIDE OF THE V. RECLAMPING OF V-BLOCK. GRINDING OF THE SECOND SIDE OF THE V. REPEATING OF THE SAME PROCEDURE FOR THE OPPOSITE V-FORM.

SCALE 1:1

MAT. CARBON STEEL

V- BLOCK

From Machinist / Shaping II

No. 3.2.4/4

SURFACE-GRINDING



DEVELOPMENT CELL FOR SKILLED LABOUR TRAINING

PAK-GERMAN TECHNICAL TRAINING PROGRAMME

MACHINIST

▽ (▽▽▽ ground)

Tolerance $\pm 0,01$
unless otherwise stated

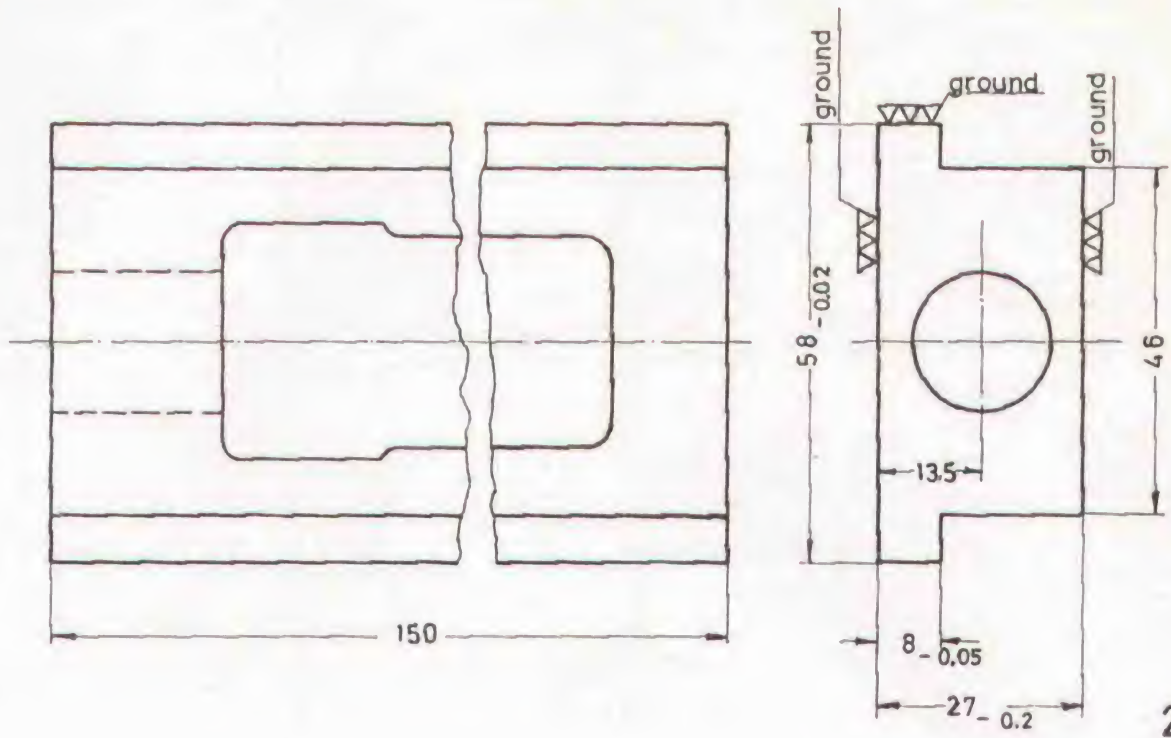

مزید کتب پڑھنے کے لئے آج ہی وزٹ کریں : www.iqbalkalmati.blogspot.com

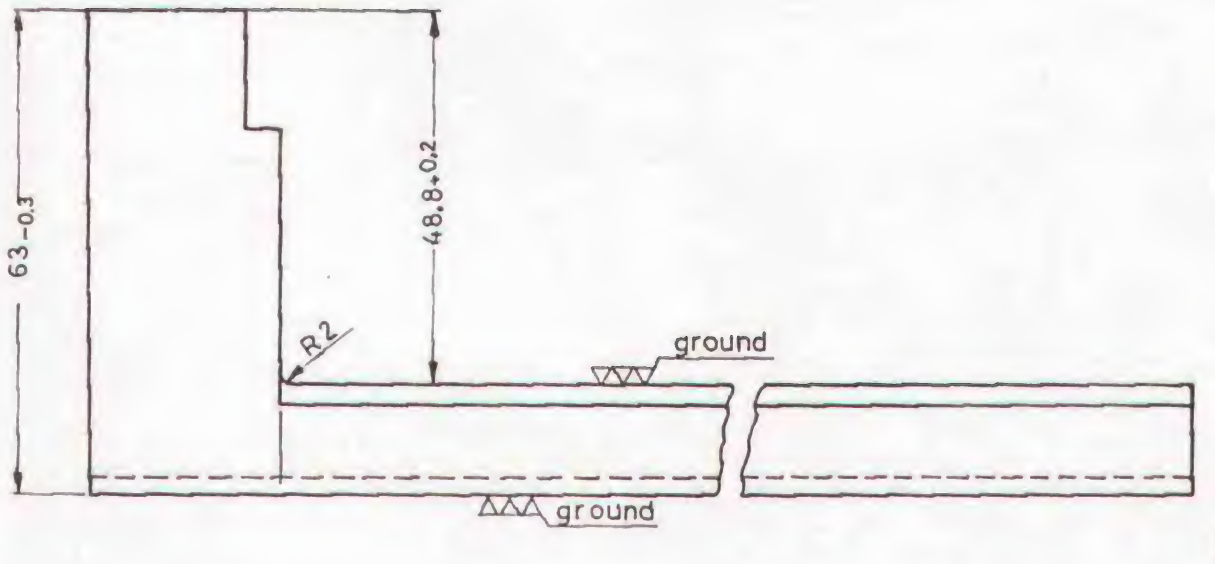

SCALE 1:1	SLIDE AND BASE OF VICE From Machinist / Milling I & Turner / Shaping II	No. 3 2.4 / 5
MAT. CAST-IRON		SURFACE-GRINDING
 DEVELOPMENT CELL FOR SKILLED LABOUR TRAINING PAK-GERMAN TECHNICAL TRAINING PROGRAMME		MACHINIST

مزید کتب پڑھنے کے لئے آج ہی وزٹ کریں : www.iqbalkalmati.blogspot.com